

ACOUSTIC ACQUISITION SYSTEM

QUALILIFE HIGHBLUE

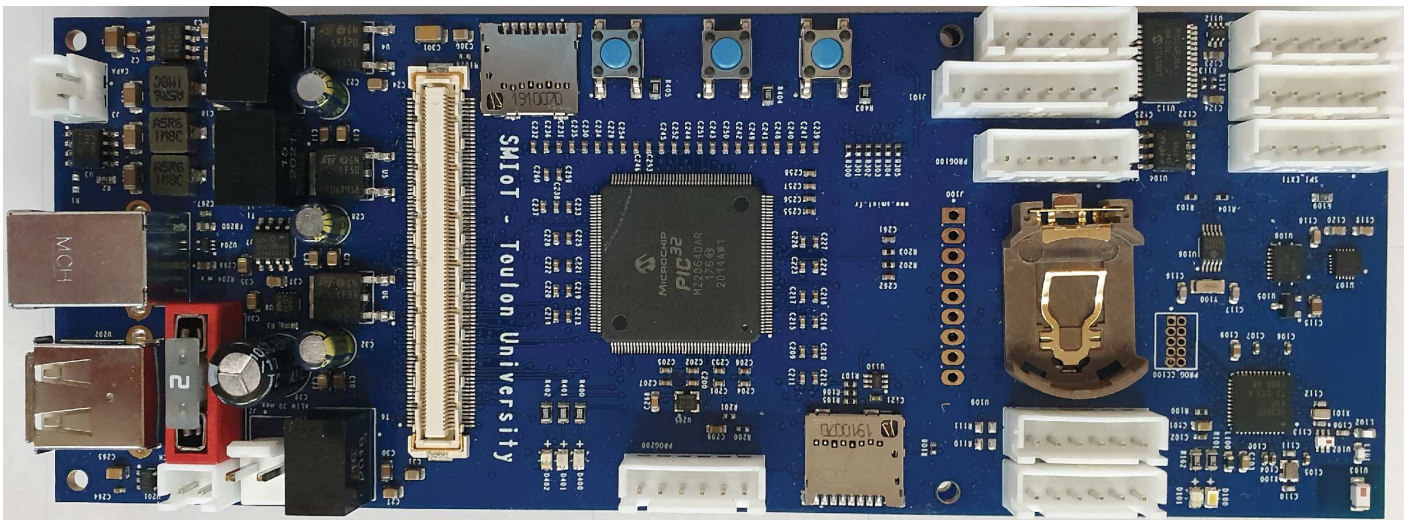

SUMMARY

Features	6
Applications	7
Connectors Description	8
On Motherboard:	8
POWER Connector (J2: "POWER IN")	8
External SWITCH Connector (J1: "Switch")	8
External Capacitor (J3: "CAPA")	9
CR2032 Connector (U109)	9
Extension Connector (U402)	10
Uart 1 Connector	10
Uart 2 Connector	11
Uart 3 Connector	11
USB Connectors	12
USB HOST Connector	12
USB Device Connector	12
On Daughter Board:	13
Extension Connector Top (U300)	13
Extension Connector Bot (U301)	13
Hydrophone/Microphone/Line Input/Differential Input/DC Output (J100, J200)	14
Hydrophone CXX:	15
Hydrophone SQ26:	16
Specifications	17
Absolute Maximum Ratings	17
ESD Ratings	17
Electrical Characteristics	18
Characteristics of input filter	18

ADC Characteristics:	18
Characteristics of anti-aliasing Filter	20
Features analog digital conversion stage:	22
Power Consumption:	23
Recording	23
USB Device Mode	23
USB Host Mode (USB HDD [Toshiba 1To])	23
Sleep Mode	24
Manual	25
Recommendations of use	25
Safety Precautions	25
Environment	25
Handling	25
Connecting cables and input / output	26
modifications	26
Precautions	27
Electrical Interference	27
Cleaning	27
Installation	28
Unpacking:	28
Installing the Hardware:	28
Installing the CR2032:	28
Stacking Multiple Daughter Boards:	29
System Startup:	30
Formatting the storage medium	30
Software Configuration:	31
Software parameters Description	32
Operation Sequence in Standalone Mode	34
Updating the date and time of the system:	34

Hardware Configuration:	35
Daughter Board Input Configuration (S101, S201)	35
Example of Configuration Of Daughter Board Input For Cxx Hydrophones (S101, S201)	35
Example of Configuration Of Daughter Board Input For SQ26 Hydrophones (S101, S201)	35
Example of Configuration Of Daughter Board Input For Differential Inputs (S101, S201)	36
Daughter Board Digital Output Routing Selection	37
One or Two Channels Configuration example:	37
Four Channels Configuration exemple:	38
For the first Daughter Board:	38
For the second Daughter Board:	38
Daughter Board Analog Gain Configuration (S100-S102, S200-S202)	39
Stop system and recovery measures	40
.Log File Descriptor	41
File Structure Overview	41
Header Description	42
Additional_DataBloc Description	43
DataBloc Description	43
Noise Measurement	44
Single Ended - Input Shorted to GND	44
GAIN X1	44
Noise spectrum in mel scale	44
GAIN X10	44
Noise spectrum in mel scale	44
Noise spectrum in mel scale	45
GAIN X100	45
Noise spectrum in mel scale	45
Noise level with single input shorted to ground is below -86dB for frequencies higher than 1kHz. This leads to 15 significant bits in x100 amplification mode.	45

Single Ended - Pure Sine Input	45
Pure sine 100mV F=1kHz	45
Gain X1	45
Waveform and spectrogram	45
Spectrum	45
Gain X10	46
Waveform and spectrogram	47
Spectrum	47
Pure sine 20mV F=1kHz	48
Gain X50	48
Waveform and spectrogram	48
Spectrum	48
Gain X100	48
Waveform and spectrogram	49
Spectrum	49
Single Ended - Sweep Input	50
Sweep sine 100mV F=1Hz to 256kHz	50
Gain X1	50
Waveform and spectrogram	50
Gain X10	50
Waveform and spectrogram	50
Sweep sine 20mV F=1Hz to 256kHz	51
Gain X50	51
Waveform and spectrogram	51
Gain X100	51
Waveform and spectrogram	51
Check-list	52

Faq	52
Guarantee	53
Remarks / Miscellaneous	53
Information on the status of LEDs:	53
Fuse Replacement:	53
NOTES:	53
Mechanical Information	54
QHB Motherboard V2 drawing	54
Orientation of Axes (IMU)	54
QHB Daughter board V2 drawing	55
QHB Daughter board V3 Drawing (Current version)	56
Contact us	57

FEATURES

ACQUISITION:

- Acquisition Sample Rate: Up to 512 Ksps
- Frequency range of the input signal: 0.5 Hz to 256 kHz.
- Acquisition resolution in 8, 16, or 24 bits adjustable via a configuration script.
- Differential acquisition with 2.5V maximum input level.
- Accurate timestamping
- Anti-aliasing filter configurable to input signal without change of input signal in the passband (see section « characteristic of Anti-Aliasing filters »).

AMPLIFIER :

- Differential amplifier
- Amplifying the signal from the hydrophone: X1, X10, X20, X100
- Single ended input and differential output
- Input impedance: 10^{13} ohm.
- Input Filter: First order High-Pass filter : Cutoff frequency = 0.96Hz

STORAGE:

- Storage support on micro SD card (or SD via an adapter)
- Storage support on USB MSD (USB Flash Drive, HDD, SCSI)
- Storage support on PC (USB Device Mode)

MOTION:

- Integrate Inertial motion sensor (9DoF)

WIRELESS:

- Integrate a BLE 4.0 chip that allow user to monitor/configure system

POWER SUPPLY:

- Power Supply range: From 7V to 35VDC

ENERGY CONSUMPTION :

- Max Power Consumption: 4W in lifelong learning (SD and hydrophone including C75, X5 channels)
- Max Power consumption: 100μW in Sleep Mode

PROCESSING:

- Support embedded processing by deep Learning

APPLICATIONS

- Vibration and Modal Analysis
- Data Acquisition Systems
- Acoustics and Dynamic Strain Gauges
- Power Quality Analysis
- Long Term Monitoring
- 3D Tracking of source
- Motion tracking

QHB Block Diagram

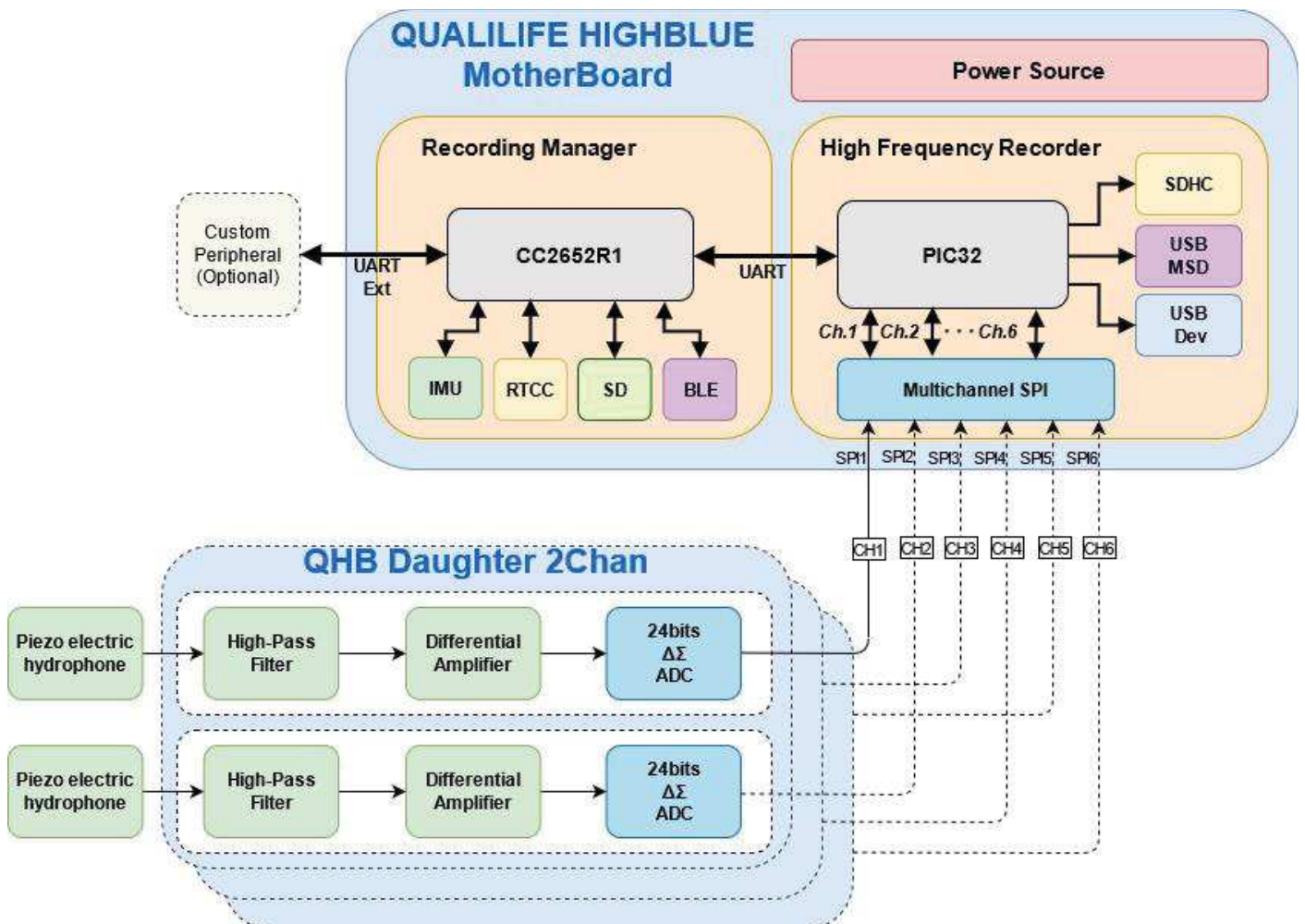

CONNECTORS DESCRIPTION

ON MOTHERBOARD:

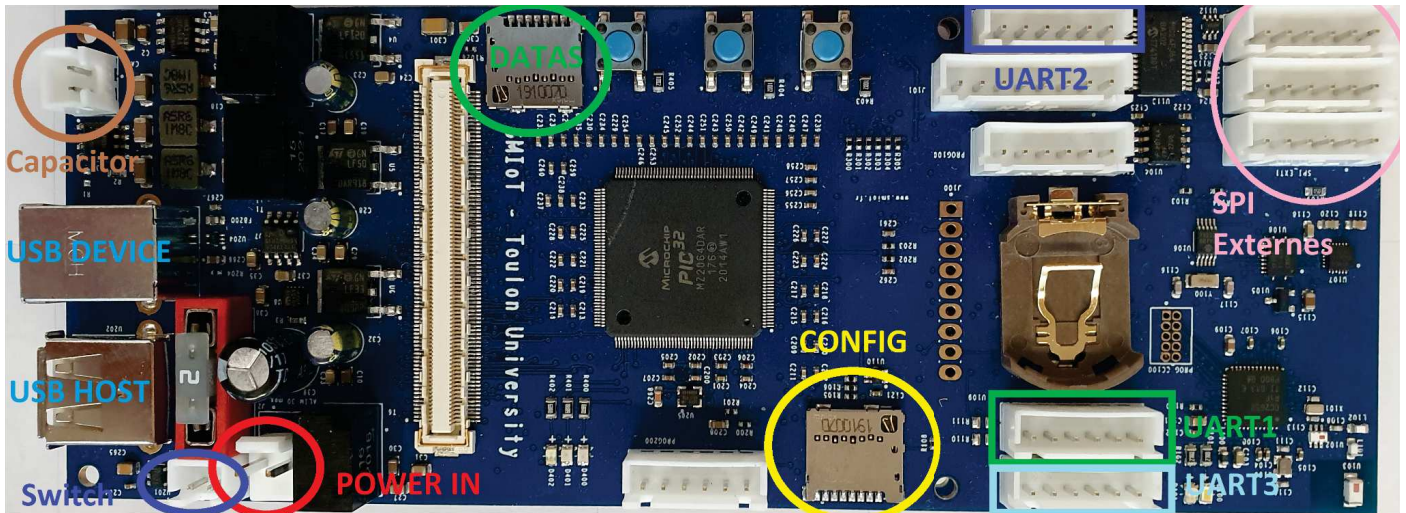

POWER CONNECTOR (J2: "POWER IN")

This Connector is the POWER Connector. It is used to provide power to the board.

It use a JST connector: **B2P-VH(LF)(SN)**

The cable to use to power the system have to be a JST: **VHR-2N**



PIN	FUNC
1	+VCC
2	GND

The voltage (VCC) should be at least **15V** (with 12V output capability), up to **35V DC**,

Or from **7V** (without 12V output capability), up to **35V DC**

EXTERNAL SWITCH CONNECTOR (J1: "SWITCH")

This connector is used to close or open the power circuit. If not used, connect the two pin together (with a jumper).

It use a JST connector: **B2B-XH-A(LF)(SN)**



QHB

The cable to use to connect the switch to the system have to be a JST: **XHP-2**

PIN	FUNC
1	VCC_IN
2	VCC_OUT

EXTERNAL CAPACITOR (J3:"CAPA")

To avoid power loss at light impacts or movements (when used in a sealed tube), a decoupling capacitor has been added to the system. This must be connected to the capture card to ensure proper operation thereof.

It use a JST connector: **B2B-XH-A(LF)(SN)**

The cable to use to connect the capacitor to the system have to be a JST: **XHP-2**

PIN	FUNC
1	+VCC
2	GND



CR2032 CONNECTOR (U109)

QHB the system has a holder for a CR2032 for saving and maintenance of the internal clock for a period of 10 to 15 years in the case of cutoff of the power supply. This battery will be necessary to maintain the time of day system (Main Switch Off), or in the case of too low power (low battery, ...).



EXTENSION CONNECTOR (U402)

There is an extension connector, used to stack multiple daughter boards to the motherboard.

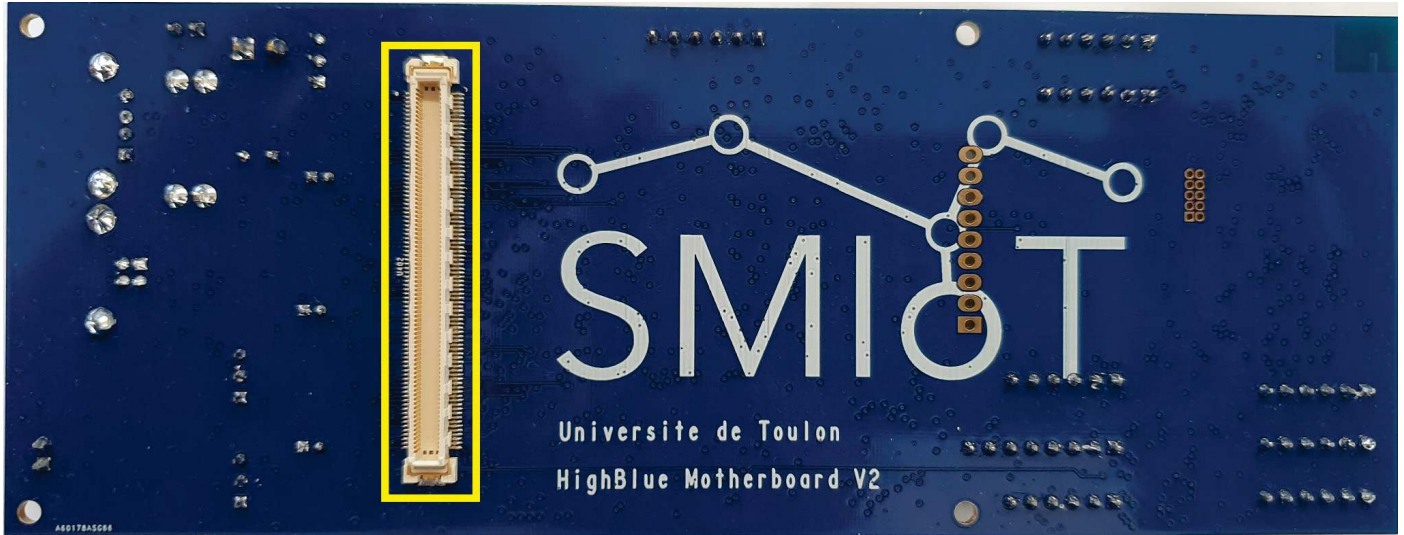

This is a 168 pin connector.

UART 1 CONNECTOR

This Connector is used to connect a GPS to QHB. (Not used yet)

It use a JST connector: **B6P-VH(LF)(SN)**

The cable to use to power the system have to be a JST: **XHP-6**

PIN	FUNC
1	+3.3V Always ON
2	GND
3	Rx1
4	Tx1
5	INT_1
6	3.3V Switched

UART 2 CONNECTOR

This Connector is used to connect a GSM to QHB. (Used in MARITIMO)

It use a JST connector: **B6P-VH(LF)(SN)**

The cable to use to power the system have to be a JST: **XHP-6**

PIN	FUNC
1	+3.3V Always ON
2	GND
3	Rx2
4	Tx2
5	INT_2
6	3.3V Switched

UART 3 CONNECTOR

This Connector is used to connect an external system to QHB. (For example a Buoy in MARITIMO)

It use a JST connector: **B6P-VH(LF)(SN)**

The cable to use to power the system have to be a JST: **XHP-6**

PIN	FUNC
1	+3.3V Always ON
2	GND
3	Rx3
4	Tx3
5	INT_3
6	3.3V Switched

USB CONNECTORS

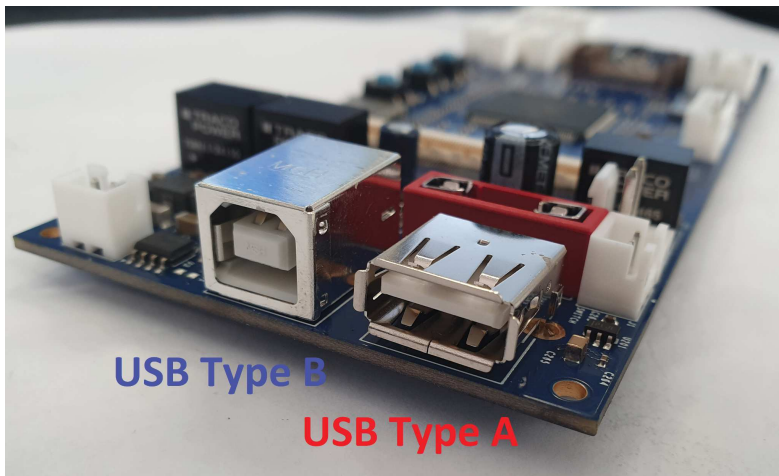

Note: Do not connect USB type A and USB Type B at the same time!!

USB HOST CONNECTOR

The USB Host Connector (USB type A) allows the user to plug a USB Flash drive or HDD/SSD to QHB as a storage device for data.

In this case, the QHB operates as “Host”, and will write data on the storage media plugged to the USB type A slot.

USB DEVICE CONNECTOR

The USB Device Connector (USB type B) allows the user to use QHB as a peripheral device from a personal computer.

In this mode, the QHB operates as a device, and it is responsible to the host to grab data from the board.

ON DAUGHTER BOARD:

EXTENSION CONNECTOR TOP (U300)

This connector is used to attach the Daughter board to the motherboard, or to another Daughter board (more than 2 channels)

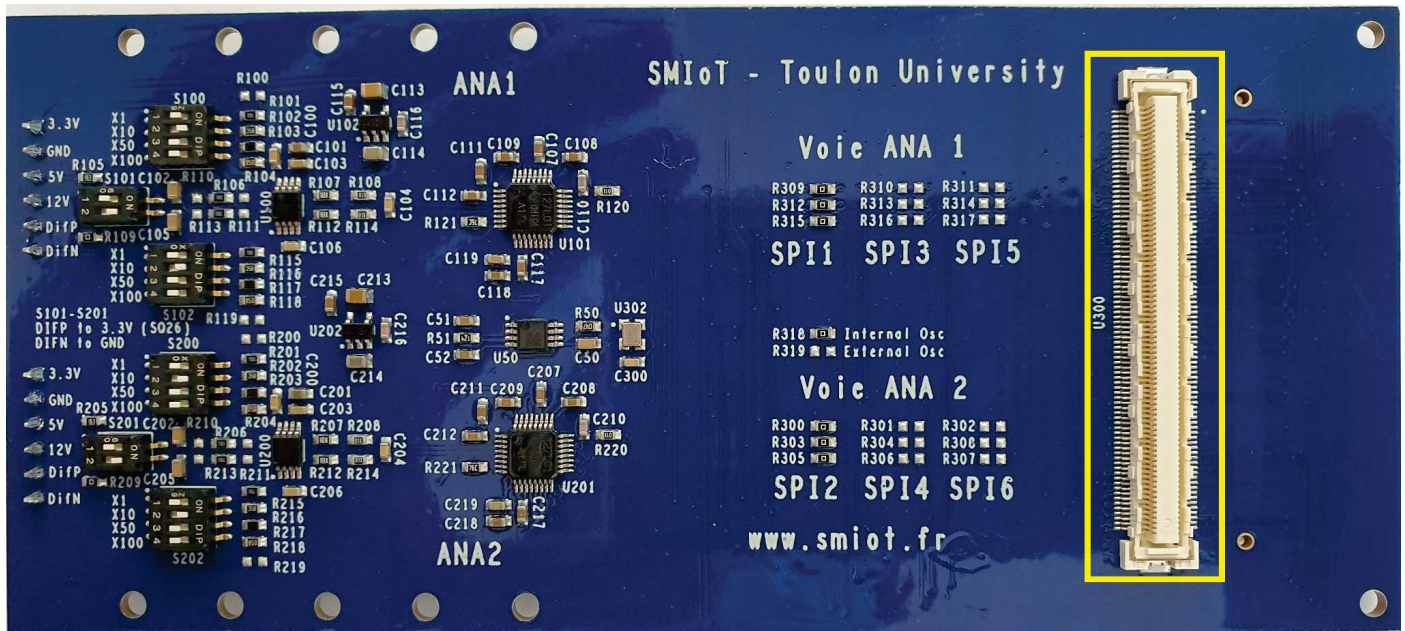

This is a 168 pin connector.

EXTENSION CONNECTOR BOT (U301)

This connector is used to attach another Daughter Board to this Daughter board (more than 2 channels)



HYDROPHONE/MICROPHONE/LINE INPUT/DIFFERENTIAL INPUT/DC OUTPUT (J100, J200)



When wiring hydrophones ensure work is accomplished in an anti-static environment, and be discharged of static load. (Avoid wool clothing and touch a point of grounding ie: PC casing, ...).

This connector is used to connect an Hydrophone, Microphone, or Line input to the acquisition board. It can also provide DC output to power hydrophone/microphone.

It use a JST connector: **B6B-XH-A(LF)(SN)**

The cable to use have to be a JST: **XHP-6**

PIN	FUNC
1	+3.3V Output
2	GND
3	+5V Output
4	+12V Output
5	DiffP (Positive Input)
6	DiffN (Negative Input)

In the case of a system in MONO configuration, the hydrophone is connected to the path "ANA1". In the case of a system configuration Stereo or more, the hydrophones are connected on both channels and/or on multiple daughter boards if more than 2 channels are used.

HYDROPHONE CXX:

Connections to QHB:

Hydrophone CXX from *Cetacean Research*[®] is a 3wire device (+VHydrophone, GND, Output signal). It accepts voltage input ranging from +5VDC to + 30VDC.

In case of a long wire between the board and the microphone (L>2 Meters), +12V output is preferred to power the hydrophone.

Otherwise +5V output is sufficient.

Wiring of J100, J200:

PIN	FUNC
1	N.C.
2	GND
3	+5V Hydrophone power (if short wire)
4	+12V Hydrophone power (if long wire)
5	DiffP Hydrophone signal
6	N.C.

For CXX, don't forget to configure the hardware input of the daughter boards.



HYDROPHONE SQ26:

Connections to QHB:

Hydrophone SQ26 from *Cetacean Research*[®] is a 2wire device (+VHydrophone/Output Signal, GND). It accepts voltage input ranging from +3.3VDC to +5VDC.



Wiring of J100, J200:

PIN	FUNC
1	N.C.
2	GND
3	N.C.
4	N.C.
5	DiffP: Hydrophone signal + power on signal
6	N.C.

For SQ26, don't forget to configure the hardware input of the daughter boards.

SPECIFICATIONS

ABSOLUTE MAXIMUM RATINGS

		MIN	MAX	Unit
Voltage	VDD to GND with 12V output supply	15	36	V
	VDD to GND without 12V output supply	7	36	V
	DIFFP to DIFFN	0	2.5	V
	Digital input	DGND-0.3	DVDD+0.3	V
	BACKUP Battery (CR2032)	1.3	3.6	V
Current	Input, continuous, any pin except power supply pins	-10	10	mA
	Timekeeping (From VBAT), VCC=0V	850	2300	nA
Température	Operating ambient, Ta	-40	100	°C

ESD RATINGS

		Value	Unit
V(ESD) Electrostatic discharge	Human-body model (HBM), per ANSI/ESDA/JEDEC JS-001	±2000	V
	Charged-device model (CDM), per JEDEC specification JESD22-C101	±1000	

ELECTRICAL CHARACTERISTICS

Minimum and maximum specifications apply from TA = -40°C to +100°C. Typical specifications are at TA = 25°C.

CHARACTERISTICS OF INPUT FILTER

QHB Daughter board comes with a High-pass input filter.

It is a first order (C-R) High-Pass filter with a Cutoff frequency of 0.96Hz. It can be customised upon demand.

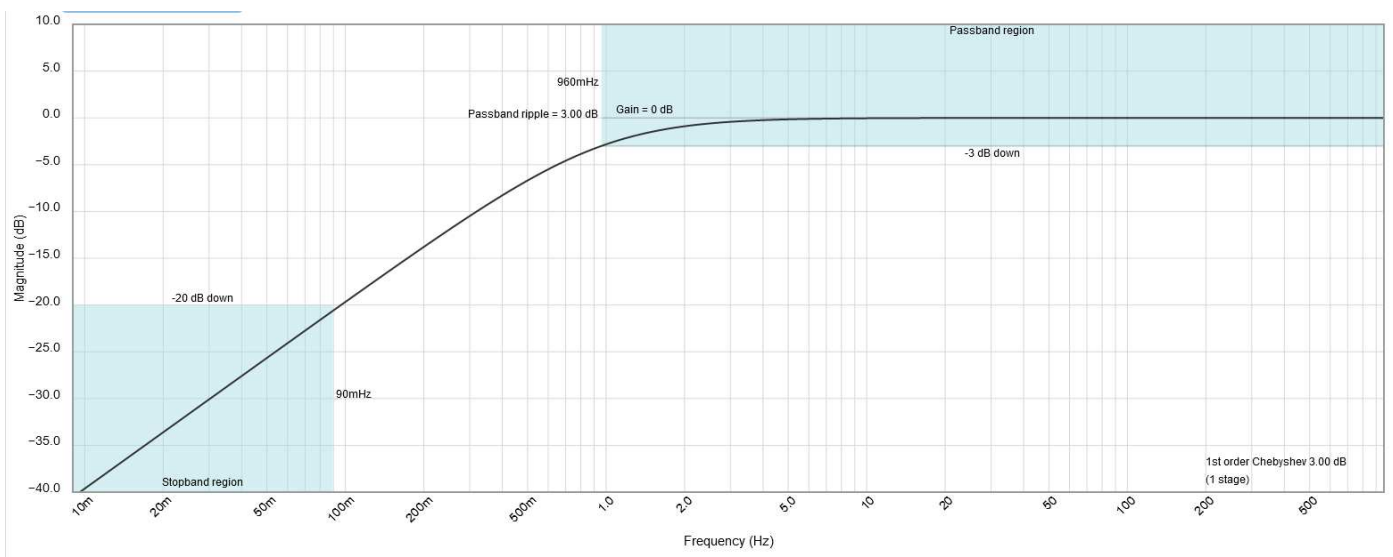

ADC CHARACTERISTICS:

PARAMETER	TEST CONDITIONS	MIN	TYP	MAX	Unit
ANALOG INPUTS					
Differential input impedance	HR mode,				
DC PERFORMANCE					
Resolution	No missing codes	8	16	24	bits
DataRate	Wideband filters	512,256,128,64			KSPS
	Low-latency filters	512,128,32,8			

QHB

Integral nonlinearity	VCM=AVDD/2		2.5	10	ppm
offset error			±0.1		mV
Offset drift			1.5	3.0	μV/°C
Noise	WB2, OSR 32		10.6		μVRMS
	WB2, OSR 64		7.3	10.1	
	WB2, OSR 128		5.1	7.2	
	WB2, OSR 256		3.6	5.2	
CMRR	Common-mode rejection ratio f _{CM} = 60Hz		95		dB
AC PERFORMANCE					
SNR	WB2, OSR 32		104.4		dB
	WB2, OSR 64	104.9	107.8		
	WB2, OSR 128	107.9	110.9		
	WB2, OSR 256	110.6	113.9		
THD	Total harmonic distortion		-113		dB

CHARACTERISTICS OF ANTI-ALIASING FILTER

Lowpass 1 (Wideband1): Cutoff frequency = $0.4 * \text{Sampling Rate}$, constant gain in the passband, high attenuation beyond so as to avoid aliasing phenomena with an attenuation of 110 dB in the stopband.

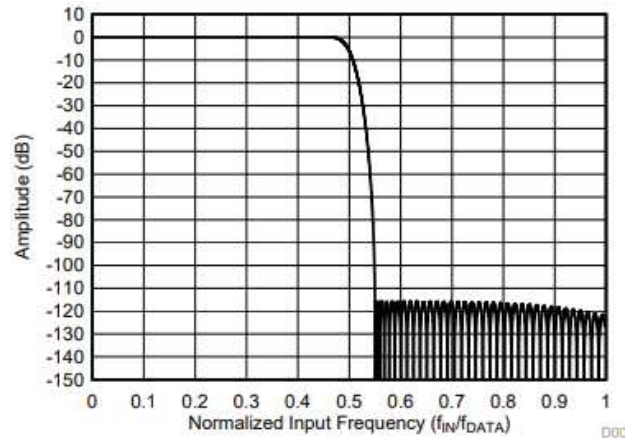

Figure 1: Transfer function of the filter WB1

Lowpass 2 (Wideband2): Cutoff frequency = $0.5 * \text{SR}$. constant gain in the passband, high attenuation beyond so as to avoid aliasing phenomena.

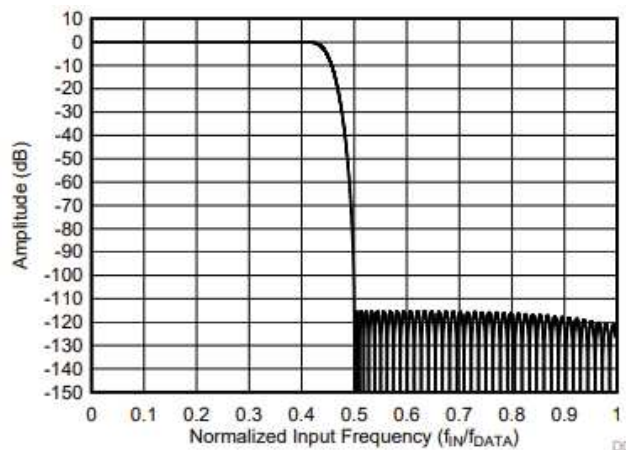

Figure 2: Transfer function of the filter WB2

QHB

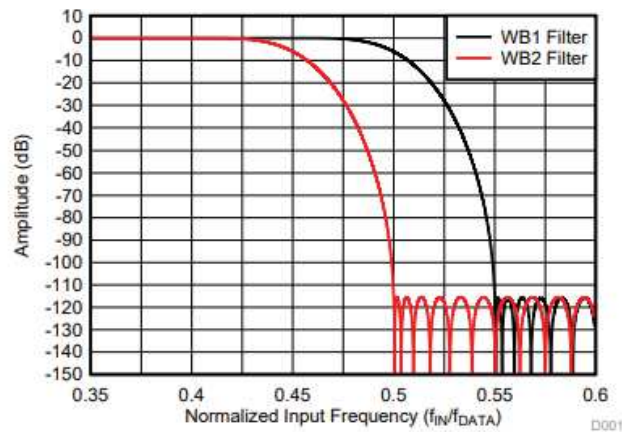

Figure 3: Comparison of transfer functions of filters WB1 and WB2

Filter Low Latency (sinc / sin5c): Constant phase shift between the output and input signals irrespective of the frequency of the input signal. In return, the gain is not perfectly consistent in bandwidth. The noise level is lower than with an anti-aliasing filter.

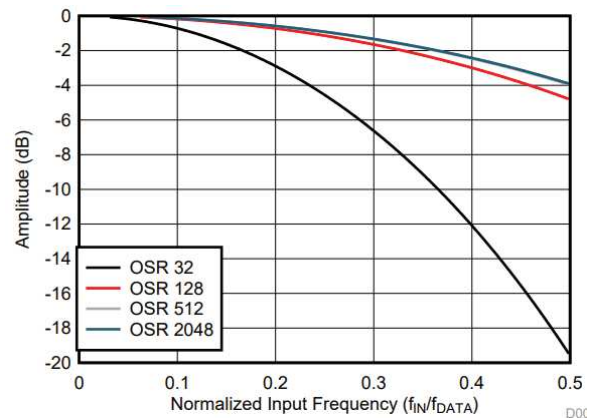

Figure 4: Filter Transfer Function Low Latency for frequencies below the Shannon limit

QHB

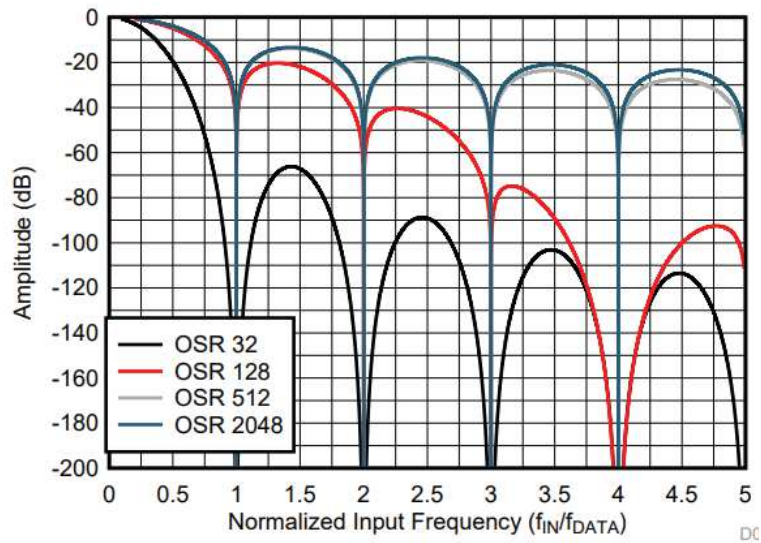

Figure 5: Filter Transfer Function Low Latency for a range of frequencies beyond the Shannon limit frequency

FEATURES ANALOG DIGITAL CONVERSION STAGE:

Table 1. Wideband Filters Performance Summary at AVDD = 3.0 V, DVDD = 1.8 V, and 2.5-V Reference

MODE	DATA RATE (SPS)	OSR	TRANSITION BAND	PASS BAND (kHz)	SNR (dB)	V _{RMS_noise} (μV _{RMS})	ENOB	I _{DVDD} (mA)
High-resolution (HR)	512,000	32	Wideband 1 filter	230.4	103.7	11.61	18.72	7.50
			Wideband 2 filter	204.8	104.1	10.64	18.84	
	256,000	64	Wideband 1 filter	115.2	107.3	7.61	19.33	4.35
			Wideband 2 filter	102.4	107.7	7.25	19.40	
	128,000	128	Wideband 1 filter	57.6	110.4	5.35	19.83	2.80
			Wideband 2 filter	51.2	110.9	5.06	19.91	
	64,000	256	Wideband 1 filter	28.8	113.4	3.79	20.33	2.00
			Wideband 2 filter	25.6	113.9	3.58	20.41	

Figure 6: acquisition noise level depending on the configuration of wideband filters

Table 2. Low-Latency Filter Performance Summary at AVDD = 3.0 V, DVDD = 1.8 V, and 2.5-V Reference

MODE	DATA RATE (SPS)	OSR	-3-dB BANDWIDTH (kHz)	SNR (dB)	V _{RMS_noise} (μV _{RMS})	ENOB	V _{pp_noise} (μV _{pp})	I _{DVDD} (mA)
High-resolution (HR)	512,000	32	101.8	107.6	7.40	19.37	64.67	1.60
	128,000	128	50.6	110.8	5.12	19.90	44.11	1.39
	32,000	512	13.7	116.2	2.74	20.80	24.14	1.33
	8,000	2048	3.5	122.0	1.41	21.76	11.32	1.32

Figure 7: Noise level of acquisition depending on the configuration of Low Latency filters

POWER CONSUMPTION:

All measurements were made with VCC=20.0V. GAIN X100 on each analog channel.

The daughter cards are not all fitted in all cases.

RECORDING

USB DEVICE MODE

	Power consumption Max(mA)					
	Chan Count	Sample Rate (KSPS)				
		512	256	128	64	32
Daughter 2&3 not mounted	1	125	121	120	118	118
	2	126	121.5	120	118	119
Daughter 3 not mounted	3	145	138	134	132	132
	4	146	139	135	133	133
Daughter 1,2 &3 mounted	5	170	158	151	148	148
	6	171	159	152	148	148

USB HOST MODE (USB HDD [TOSHIBA 1To])

The following measures include Hard drive consumption. (Model: Toshiba DTB310)

	Power consumption Max(mA)					
	Chan Count	Sample Rate (KSPS)				
		512	256	128	64	32
Daughter 2&3 not mounted	1	228	215	206	210	224
	2	230	221	213	210	223
Daughter 3 not mounted	3	242	238	230	224	242
	4	242	236	233	225	242.5

QHB

Daughter 1,2 &3 mounted	5	275	251	244	237	262
	6	275	252	246	240	263

SLEEP MODE

Power consumption in sleep mode includes RTCC Timekeeping.

Power consumption Max(mA)	
With RTCC Timekeeping	5.84

MANUAL

RECOMMENDATIONS OF USE

SAFETY PRECAUTIONS

In this manual, the warning signs and caution should be read by users to avoid dangerous accidents and problems. The meaning of these symbols is as follows:



Attention

If users ignore this symbol and mishandle the device, it can result in personal injury and damage to equipment.

Please read the safety tips and the following precautions to ensure a safe use of the JASON system.

FOOD: The power consumption of this device is low. It should only be operated by being powered by a type of continuous supply of 12 to 35V (or Li Ion / Batteries / battery according to the application, contact us).

- Lead acid batteries must be recharged using a 12V battery charger.
- When you disconnect the battery to perform charging, grasp the connector on the electronic board and never pull on the cable.
- Use a conventional 12V lead acid battery without changing the power cables.
- The QHB system can not be used to recharge the batteries.
- In case of no use, remove the batteries from the system.

ENVIRONMENT

To avoid problems and malfunctions, avoid using the system in an environment where it will be exposed to:

- Extreme temperatures (<-15 ° C;> 60 ° C)
- Heat sources such as radiators or stoves
- Excessive vibration or shock

HANDLING

- Do not place any objects filled with liquids, such as vases, on the open, as this may cause electric shock.
- Never place naked flame sources, such as lighted candles on the system as this may cause a fire.
- The QHB system is a precision instrument. Be careful not to drop or subject it to shock or excessive pressure, as this could cause serious problems.
- Make sure that no foreign objects (coins or pins etc.) or liquid (water, soft drinks and fruit juices) penetrate the unit.

CONNECTING CABLES AND INPUT / OUTPUT

You should always turn off the system and all other equipment before connecting or disconnecting cables. Be sure to disconnect all connection cables and turn off the power before moving the system.

MODIFICATIONS

Never attempt to modify it in any way. It may cause damage and be dangerous for the user.

PRECAUTIONS

ELECTRICAL INTERFERENCE

For security reasons, the system QHB was designed to provide maximum protection against the electromagnetic radiation from the device and to protect against external interference. However, any equipment that is very sensitive to electronic interference or that emits strong electromagnetic waves must not be placed near the system because the possibility of interference can not be completely eliminated. With any type of digital control device, including the QHB, electromagnetic interference can cause malfunctioning and corrupt or destroy data. Care must be taken to minimize the risk of damage.

CLEANING

Use a dry, soft cloth to clean the system. If necessary, dampen the cloth slightly. Do not use abrasive cleaners, waxes or solvents (such as paint thinner or cleaning alcohol), since these materials may dull the finish, damage the surface or cause damage to the PCB.

Please keep this manual in a safe place for future reference.

INSTALLATION

UNPACKING:

As with any electronic device, you should take care to handle this equipment carefully. Before removing the device from its packaging, discharge yourself of any static charge using a wrist strap or by simply touching the computer chassis or other grounded object to eliminate any stored static charge. Contact us immediately if any components are missing or damaged.

INSTALLING THE HARDWARE:

The hardware of the system should be delivered already assembled. No additional installation is required, except in certain cases. Only the connection of the IO and power supply should be required.

INSTALLING THE CR2032:

To install the CR2032 battery, please follow the steps below:

1. Turn ON Power on board
2. Update the system time by software or configuration script
3. Place the coin battery
4. Turn off the power



Note: The system has to be powered before placing the backup battery.

To place the coin battery on board, please insert it under the tongue then press it.

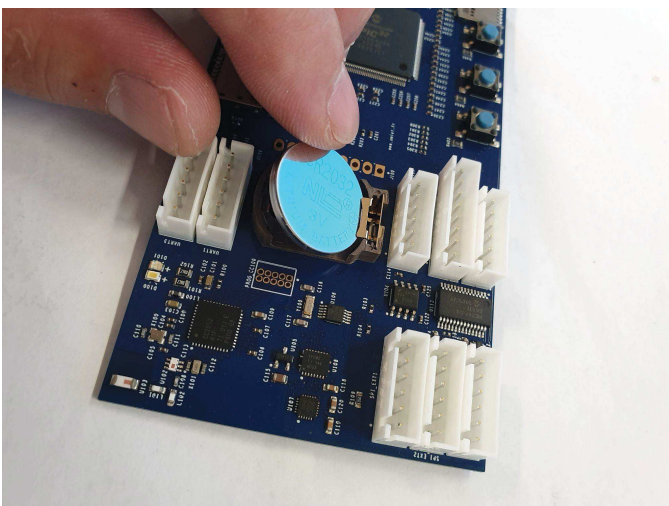

STACKING MULTIPLE DAUGHTER BOARDS:

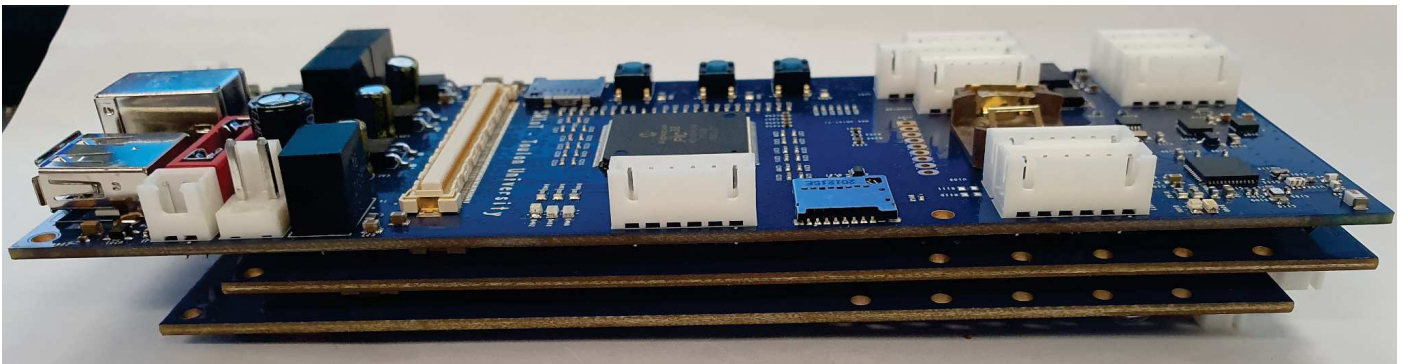
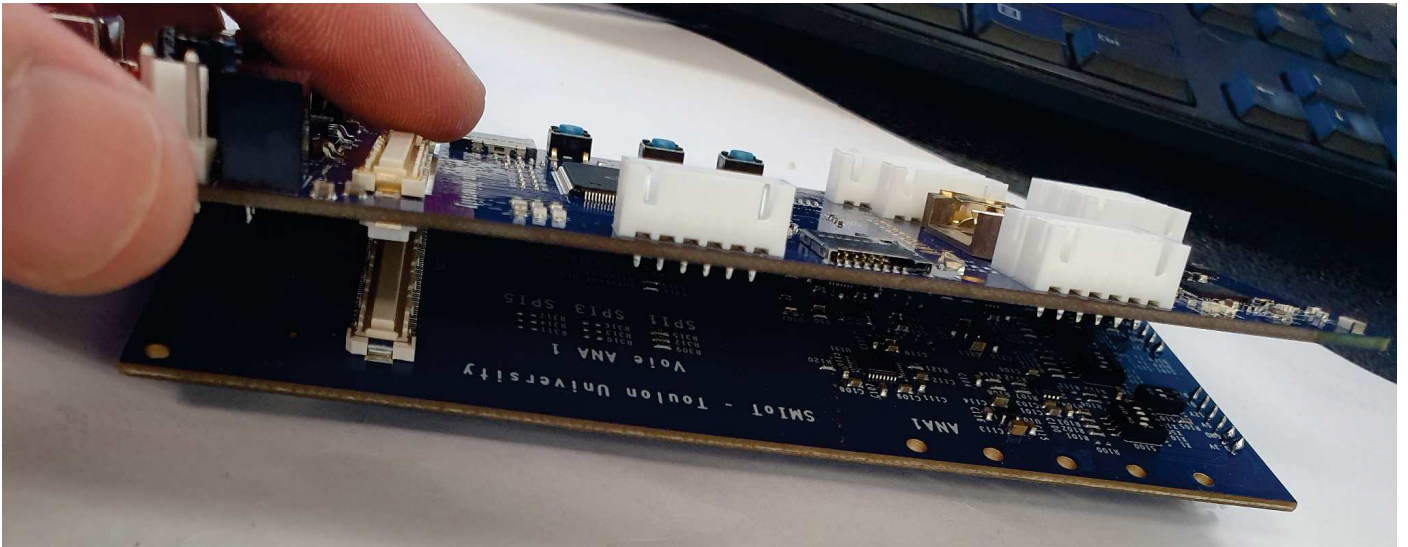

SYSTEM STARTUP:

Commissioning is very simple. Please accomplish the following steps in order:

FORMATTING THE STORAGE MEDIUM

The QHB system takes into account the FAT / FAT32 /exFAT file systems. It is therefore recommended to format the storage media to use **exFAT**.

Please preferably use fast storage media to benefit from a high transfer rate, and avoid packet loss (eg Western Digital Element 1TB).

Formatting can be done via the Windows format utility (right click on the media to format):

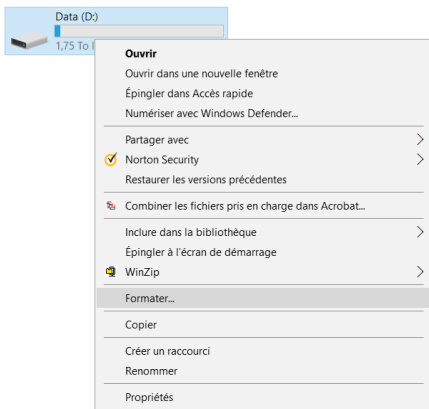

Go to the desktop of your system, right-click the storage media format -> "Format".

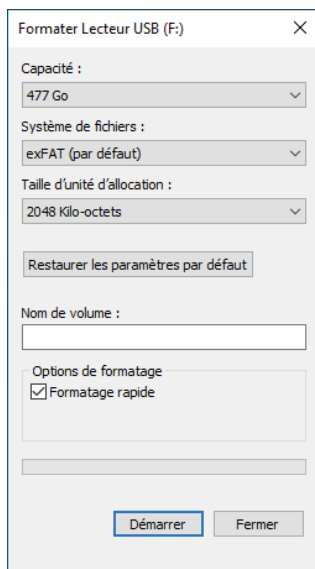

Select a unit of allocation of **2048ko**.

Click "Start".

Wait for the media to be formatted.

SOFTWARE CONFIGURATION:

The system parameter (and / or updates) via the text configuration file "JConfig.CFG" given below :

WARNING: This file is placed in the « Config » folder. Its content is "Case sensitive"

```
//System Configuration File
Sampling_Resolution=16; // 16 = Resolution in bits (8 or 16)
Sampling_Freq=256000; // 256000 = Sampling frequency(in sample
//per sec). Possibles values are
//512000,256000, 128000,64000 With WidBand
//Filters, or 512000,
//128000,32000,8000 With Low Latency
//filter
Filter_Selection=1; // = 1 ; filter selection. Possibles
//values are:
//0->Wideband1 (0.45 to0.55)*fDATA
//1->Wideband2 (0.40 to0.50)*fDATA
//2->LowLatency

AutoStart=true; // = true = Auto record at boot
FILE_Size_Limit=150000000; //File Size limitation (in
//bytes) = 150000000 for 5
//minutes
Record_Use_TimeInterval=true; //Set or unset the discrete
recording
Shutdown_Duration=5; //Time period of wait time
between each record (in
seconds)
Preparing_Duration=5; //Time to boot and prepare Pic 32 (SD Card
or HDD is not the same)
Recording_Duration=5; //Time period of record (in seconds)
Stopping_Duration=5; //Time to stop Pic 32 (SD Card or HDD is
not the same)
Channel_Count=2; //Number of channels to record
Storage_Target=SD; //Storage target (SD for SD card, HDD
for hard disk drive or USB for Device
//mode)
```

If this file is not present, the recordings will not start.

This file has to be placed in the "**Config**" μSD card slot.

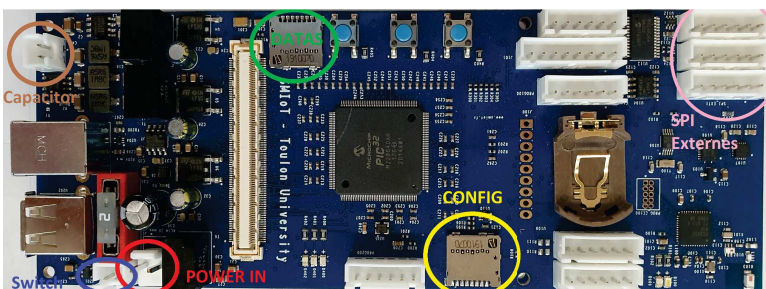

SOFTWARE PARAMETERS DESCRIPTION

The following tab describes the customizable parameters of QHB.

Parameter Name	Description										
Sampling_Resolution	this configures the sampling resolution in bits.										
	Possibles values are:										
	24										
	16										
	8										
Sampling_Freq	This is the sampling frequency in Sample per second. Possibles values are:										
	<table border="1"> <thead> <tr> <th>With Wideband filter</th> <th>With Low Latency Filter</th> </tr> </thead> <tbody> <tr> <td>512000</td> <td>512000</td> </tr> <tr> <td>256000</td> <td>128000</td> </tr> <tr> <td>128000</td> <td>32000</td> </tr> <tr> <td>64000</td> <td>8000</td> </tr> </tbody> </table>	With Wideband filter	With Low Latency Filter	512000	512000	256000	128000	128000	32000	64000	8000
	With Wideband filter	With Low Latency Filter									
	512000	512000									
	256000	128000									
	128000	32000									
64000	8000										
Filter_Selection	This sets the anti aliasing filter. Possibles values are:										
	<table border="1"> <thead> <tr> <th>Value</th> <th>Description</th> </tr> </thead> <tbody> <tr> <td>0</td> <td>Wideband1 (0.45 to 0.55 x fDATA)</td> </tr> <tr> <td>1</td> <td>Wideband2 (0.40 to 0.50 x fDATA)</td> </tr> <tr> <td>2</td> <td>LowLatency</td> </tr> </tbody> </table>	Value	Description	0	Wideband1 (0.45 to 0.55 x fDATA)	1	Wideband2 (0.40 to 0.50 x fDATA)	2	LowLatency		
	Value	Description									
	0	Wideband1 (0.45 to 0.55 x fDATA)									
	1	Wideband2 (0.40 to 0.50 x fDATA)									
2	LowLatency										
AutoStart	This parameter allow the system to start recording										

QHB

	<p>automatically upon power on.</p> <table border="1"> <thead> <tr> <th>Value</th> <th>Description</th> </tr> </thead> <tbody> <tr> <td>true</td> <td>Record will automatically start at boot</td> </tr> <tr> <td>false</td> <td>Record will not start automatically</td> </tr> </tbody> </table>	Value	Description	true	Record will automatically start at boot	false	Record will not start automatically
Value	Description						
true	Record will automatically start at boot						
false	Record will not start automatically						
FILE_Size_Limit	This indicates the maximum file size in bytes. (file will be splitted)						
Record_Use_TimeInterval	<p>This set or not the discrete recording mode.</p> <table border="1"> <thead> <tr> <th>Value</th> <th>Description</th> </tr> </thead> <tbody> <tr> <td>true</td> <td>Enable discrete recording</td> </tr> <tr> <td>false</td> <td>Continuous recording</td> </tr> </tbody> </table>	Value	Description	true	Enable discrete recording	false	Continuous recording
Value	Description						
true	Enable discrete recording						
false	Continuous recording						
Shutdown_Duration	This set the time of sleep period (in seconds)						
Preparing_Duration	Time to boot and to prepare filesystem (in seconds)						
Recording_Duration	Time of the record period (in seconds)						
Stopping_Duration	This set the time to let the system to flush DDR and close file (in seconds)						
Channel_Count	This set the number of Channels to acquire.						
Storage_Target	<table border="1"> <thead> <tr> <th>Value</th> <th>Description</th> </tr> </thead> <tbody> <tr> <td>SD</td> <td>This sets the system to save data on USB Flash drive or Data SD Card. (standalone Mode)</td> </tr> <tr> <td>USB</td> <td>This sets the system to use Device Mode. (Peripheral Mode)</td> </tr> </tbody> </table>	Value	Description	SD	This sets the system to save data on USB Flash drive or Data SD Card. (standalone Mode)	USB	This sets the system to use Device Mode. (Peripheral Mode)
Value	Description						
SD	This sets the system to save data on USB Flash drive or Data SD Card. (standalone Mode)						
USB	This sets the system to use Device Mode. (Peripheral Mode)						

OPERATION SEQUENCE IN STANDALONE MODE

The graph below indicates how the system operates in “standalone” and “Discrete recording” mode.

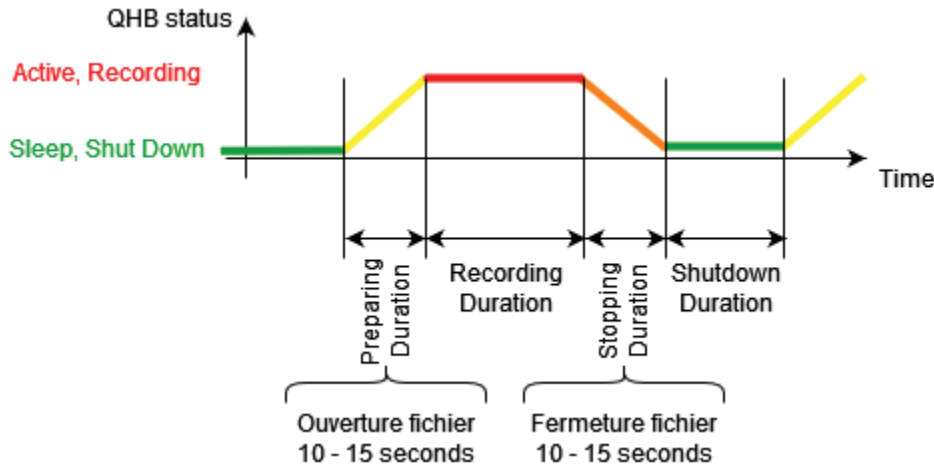

UPDATING THE DATE AND TIME OF THE SYSTEM:

The system set or updates board current Time via a text configuration file "CLOCK.CFG" in the following form:

```
CLOCKTIME= 11/02/2018 10:02:00;
```

To update the system, the CLOCK.CFG file must be placed in the Config folder. Then insert the mass storage in QHB, and turn-ON the system.

The system will read the content of the CLOCK.CFG, update Time, then delete it. The date and time are kept current as the battery backup (CR2032) is present on the system.

HARDWARE CONFIGURATION:

On the Daughter boards, there are some Dip Switches that should be configured depending on usage.

DAUGHTER BOARD INPUT CONFIGURATION (S101, S201)

There are Two configuration DIP Switch (S101, S201) on the board.

Switch number	“ON”	“Off”
1	Superposing 3.3V on Signal (SQ26)	Others
2	Connect DiffN to GND (Single Ended Input)	Differential Input

EXAMPLE OF CONFIGURATION OF DAUGHTER BOARD INPUT FOR Cxx HYDROPHONES (S101, S201)

When using a **CXX** Hydrophone, the daughter board have to be configured for single input without superposing VCC on Signal like follow:

Switch number	State
1	“Off”
2	“ON”

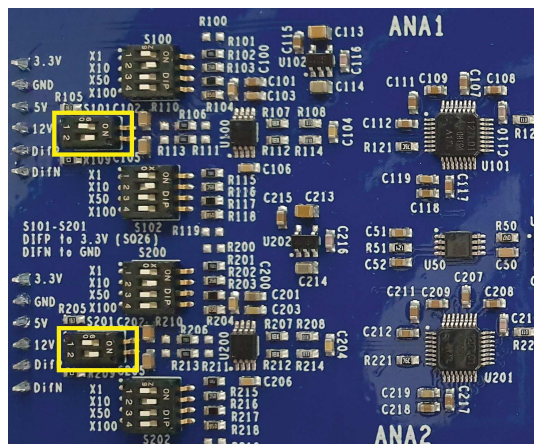

This configuration also work for Line Input.

EXAMPLE OF CONFIGURATION OF DAUGHTER BOARD INPUT FOR SQ26 HYDROPHONES (S101, S201)

When using a **SQ26** Hydrophone, the daughter board have to be configured for single input without superposing VCC on Signal like follow:

Switch number	State
1	“ON”
2	“ON”

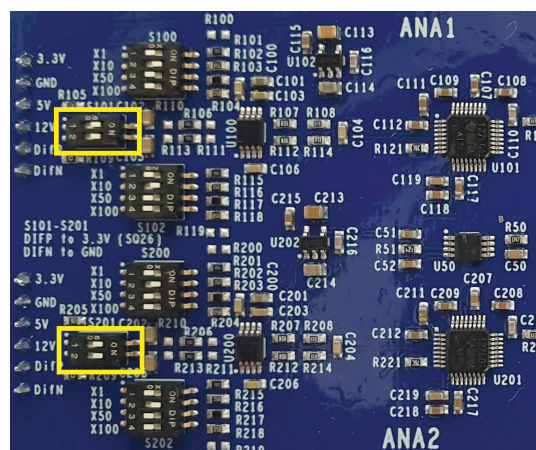

EXAMPLE OF CONFIGURATION OF DAUGHTER BOARD INPUT FOR DIFFERENTIAL INPUTS (S101, S201)

When using a differential input, the daughter board have to be configured for differential input without superposing VCC on Signal like follow:

Switch number	State
1	“Off”
2	“Off”

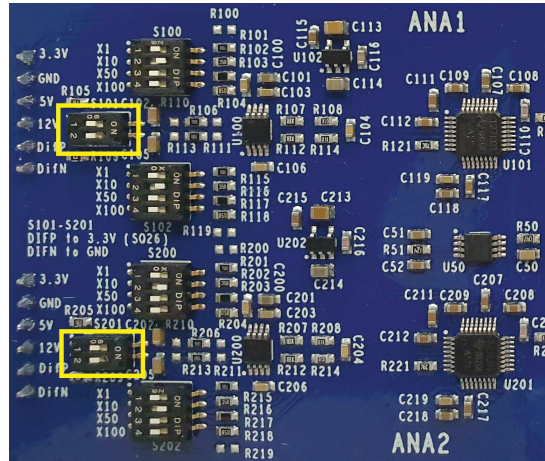

DAUGHTER BOARD DIGITAL OUTPUT ROUTING SELECTION

This is the only one hardware modification that is possible to do according to the use case.

This applies when the number of channels needed is more than 2.

As the daughter cards are all identical, it is necessary to assign them a digital channel. To do this, a small hardware modification may be necessary.

Indeed, on the boards, switching resistances are present for this purpose. They allow you to route an output channel to a specific input on the motherboard.

The Routing of the channels have to be ordered.

ONE OR TWO CHANNELS CONFIGURATION EXAMPLE:

For example, if only one or two channels are needed, these channels have to be routed to SPI1 and SPI2, and **must use internal OSC.**

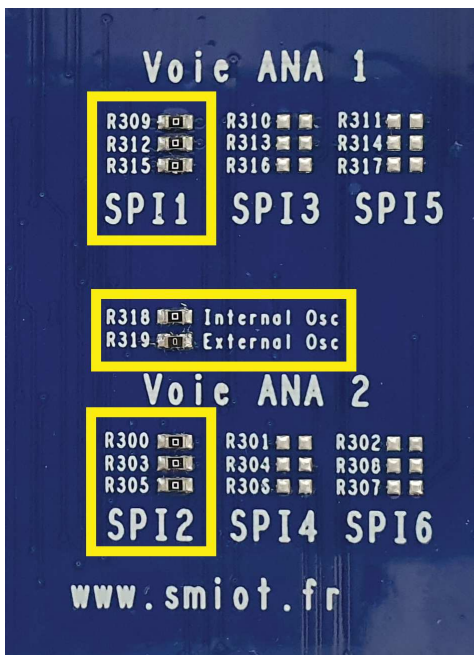

This indicate that ANA1 is routed to SPI1

This indicates that the ADC uses it's internal OSC. This indicate that the OSC of this board is routed to other boards (if present)

This indicate that ANA2 is routed to SPI2

FOUR CHANNELS CONFIGURATION EXEMPLE:

For example, if four channels are needed, these channels have to be routed to SPI1 and SPI2, SPI3 and SPI4, First Daughter board have to use internal OSC and have to provide OSC for other Daughter boards.

FOR THE FIRST DAUGHTER BOARD:

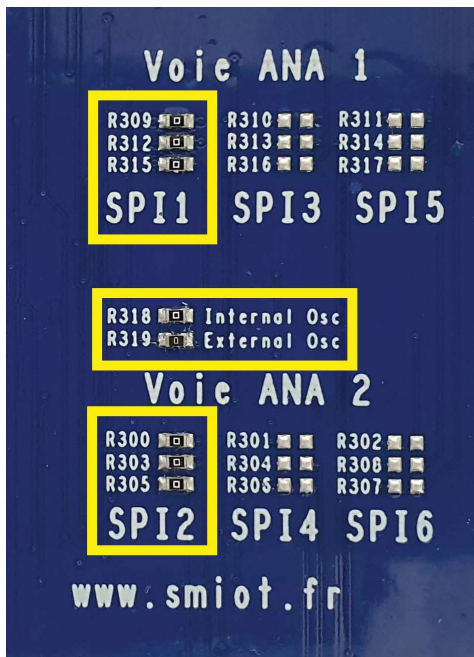

This indicate that ANA1 is routed to SPI1

This indicates that the ADC uses it's internal OSC. This indicate that the OSC of this board is routed to other boards (if present)

This indicate that ANA2 is routed to SPI2

FOR THE SECOND DAUGHTER BOARD:

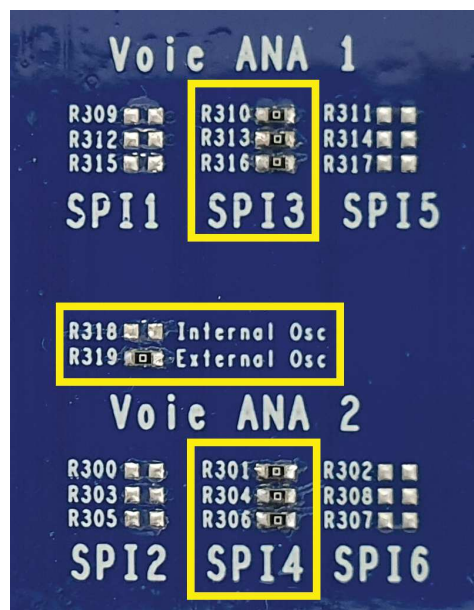

This indicate that ANA1 (of the second board) is routed to SPI3

This indicates that the ADCs use the OSC provided by other Daughter Board.

This indicate that ANA2 (of the second board) is routed to SPI4

DAUGHTER BOARD ANALOG GAIN CONFIGURATION (S100-S102, S200-S202)

There are Four configuration DIP switches (S100-S102, S200-S202) on the board. They allow users to customize input Gain.

The switches are working by pair. So S100 and S102, S200 and S202 MUST Have the same value.

Switch number				Gain Value
1	2	3	4	A (dB)
0	0	0	0	Do Not Use
1	0	0	0	X1 (1dB)
0	1	0	0	X10 (20dB)
0	0	1	0	X50 (34dB)
0	0	0	1	X100 (40dB)
1	1	0	0	X0.9(-0.91dB)
1	1	1	0	X0.89 (-1dB)
1	1	1	1	X0.89 (-1dB)
0	1	1	0	X8.32 (18dB)
0	1	1	1	X7.68 (17dB)
0	0	1	1	X33.27 (30dB)
Others				Do Not Use

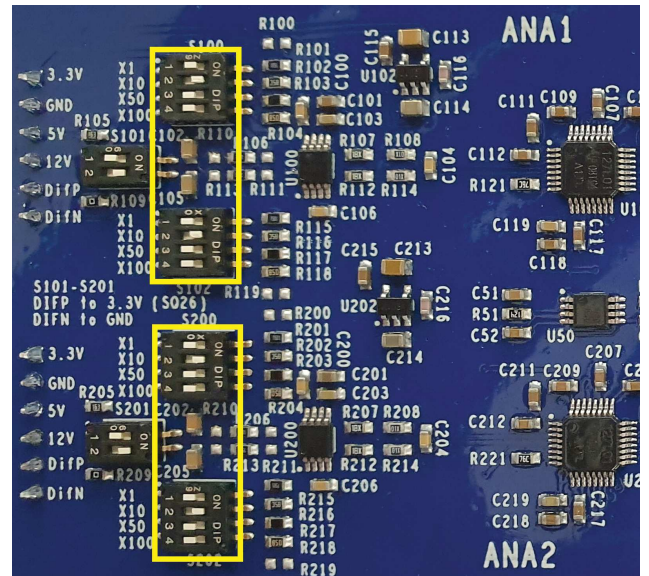

SYSTEM STARTUP

If "Autostart" = true, then the system will start the recordings with the parameters of the configuration file from its power.

Orange LED located on the capture card should light indicating that the system is recording.

STOP SYSTEM AND RECOVERY MEASURES

For powering down the tube under water, it is sufficient to rotate the cap on the top of tube tape counterclockwise (white arrow).

All LEDs on the card must go out. The measured data is saved continuously on the μ SD storage system. These are directly saved as a .log file.

Note: During the shutdown, it is possible that the last record is lost. This is why it is necessary to ensure enough wait time after the start of a record (greater than or equal to the parameter "Record_time"), or else to have a "FILE_SIZE_LIMIT" reduced (which has the effect of cutting the recording file size).

To recover the data on the card μ SD, refer to the next chapter "of the tube opening procedure".

.LOG FILE DESCRIPTOR

FILE STRUCTURE OVERVIEW

The .log file is a binary file that contains audio datas, information about record (sampling frequency, resolution, ...), as well as size of fields which made it up (Header size, DataBloc size,...).

Fichier .log
Header
Additional_DataBloc 1
DataBloc 1
Additional_DataBloc 2
DataBloc 2
.
.
.
Additional_DataBloc N
DataBloc N

HEADER DESCRIPTION

Header is the file structure descriptor. It contains information about records, and technical information about the .log file itself.

The Header contains the following fields (ordered):

Length (bytes)	Type	Nom	Description	
4	ulong	headerSize	Size of header this field <u>excluded</u> .	
2	ushort	versionNumber	Software revision	
			Octet 1	Octet 0
			Major Rev	Minor Rev
1	uchar	numberOfChan	Channels count used during record	
1	uchar	resolutionBits	Résolution of record (in bits)	
4	ulong	samplingFrequency	Sampling Frequency (in Sample per sec)	
4	ulong	dmaBlockSize	Size of DMA bloc. (Bloc that contains audio datas, grouped together in a sub-block for each of the channel)	
4	ulong	sizeOfAdditionalDataBuffer	Size of additional data bloc. (Datas IMU, GPS, others,...)	
1	uchar	numberOfExternalPeripheral	Number of external peripheral (IMU, ...)	
4	ulong	timeStampOfStart	TimeStamp local (timeStamp du High Frequency Recorder) du debut d'enregistrement.	
Variable	PERIPHERAL_CONFIGURATION[]	periphConfig[]	Tableau de structure de type PERIPHERAL_CONFIGURATION contenant la configuration de chacun des périphériques externes. Tableau de "numberOfExternalPeripheral" PERIPHERAL_CONFIGURATION	

ADDITIONNAL_DATABLOC DESCRIPTION

The Additional DataBloc contains datas coming from external sensors such as IMU, GPS, ...
 They are written in the same file as audio data (.log file) which allow synchronisation between various units.
 (Audio data, light data, absolute position, ...)
 The datas contained in this block are formatted like a simple frame defined by the UTLN protocol.
 The size of this block is defined in the header of the file.
 By default, the additional bloc size is **736** bytes, and can contain null values if no additional data are inserted in dataflow..

DATABLOC DESCRIPTION

The DataBloc is the block that contains audio datas. They are of variable length (of the size indicated by the field "dmaBlockSize" of Header), In the current configuration, the default size is **65536** octets.
 Those blocks are splitted by the number of channels.

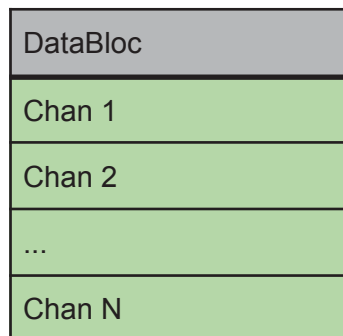

The audio length contained in one DataBloc it varies according to:

- Sampling Frequency
- Channels count
- Acquisition resolution

This length can be calculated by the following manner:

$$t = \frac{dmaBlockSize \div numberOfChan}{resolutionBits \div 8} \times \frac{1}{samplingFrequency}$$

Expression of number of DMABloc contained in a file:

$$nbBlock = \frac{(Record\ length \times samplingFrequency \times numberOfChan \times \frac{resolutionBits}{8})}{dmaBlockSize}$$

Expression of file size (in bytes) according to parameters:

$$Size = nbBlock \times (dmaBlockSize + sizeOfAdditionnalDataBuffer) + headerSize + 4$$

NOISE MEASUREMENT

Measurement are done with $VCC=20.0V$, $F_s=512000SPS$, $res=24$ bits

SINGLE ENDED - INPUT SHORTED TO GND

In this part, maximum signal level ($\pm 2.5V$) corresponds to 0dB.

GAIN X1

NOISE SPECTRUM IN MEL SCALE

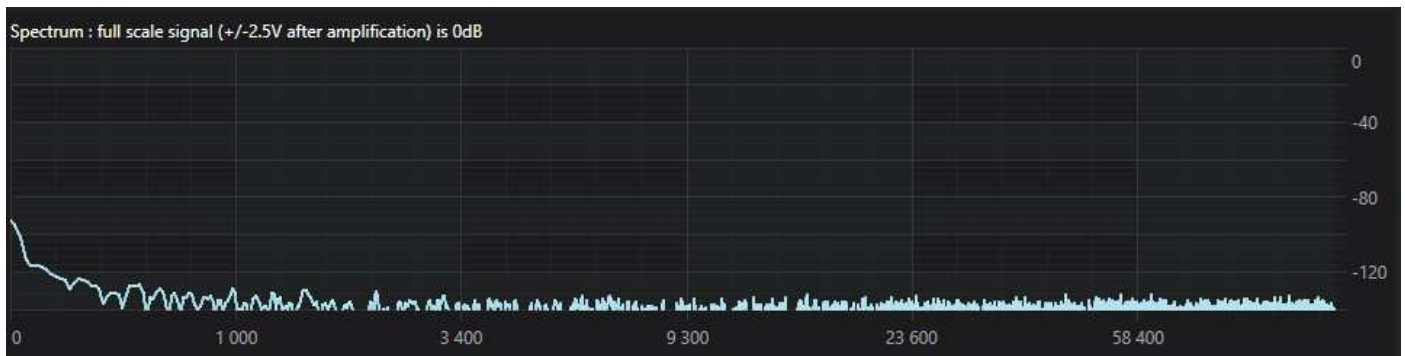

Noise level with single input shorted to ground is below -126dB for frequencies higher than 1kHz, and below -120dB for frequencies up to 1kHz. This leads to 21 significant bits in x1 amplification mode.

GAIN X10

NOISE SPECTRUM IN MEL SCALE

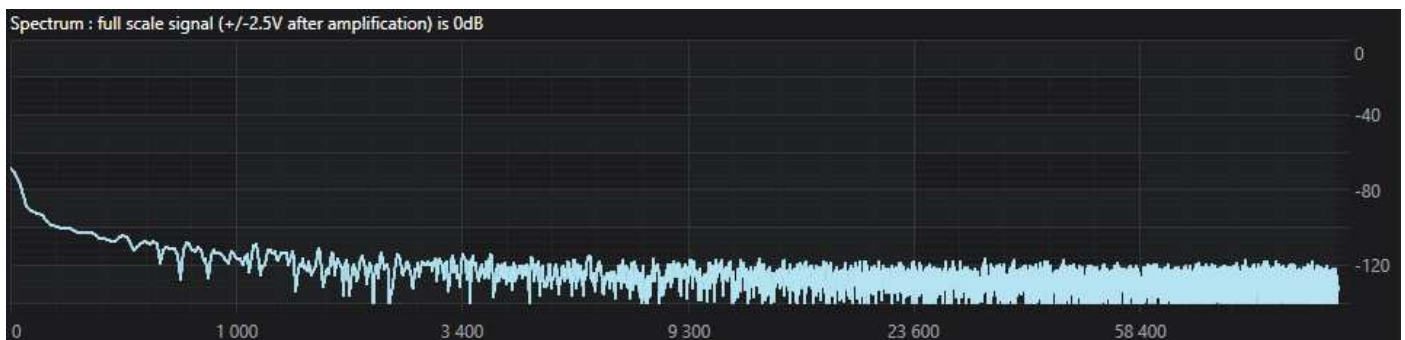

Noise level with single input shorted to ground is below -106dB for frequencies higher than 1kHz. This leads to 18 significant bits in x10 amplification mode.

GAIN X50

NOISE SPECTRUM IN MEL SCALE

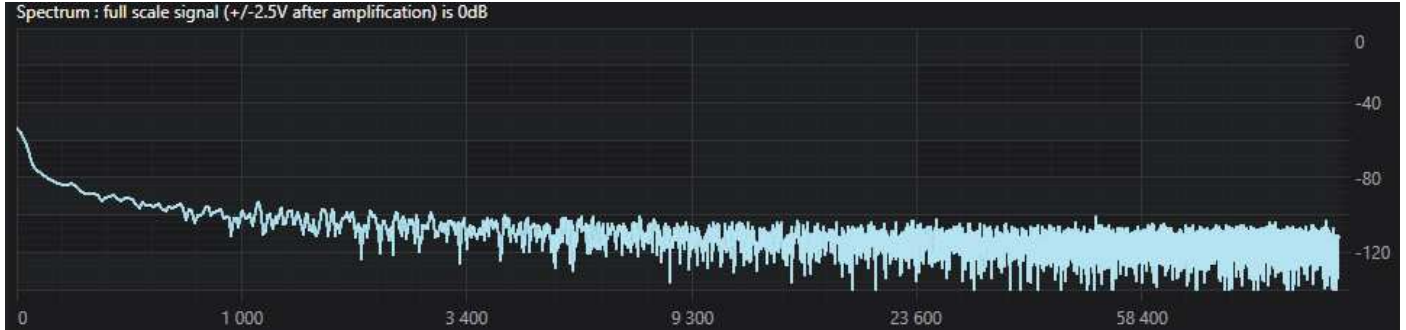

Noise level with single input shorted to ground is below -92dB for frequencies higher than 1kHz. This leads to 16 significant bits in x50 amplification mode.

GAIN X100

NOISE SPECTRUM IN MEL SCALE

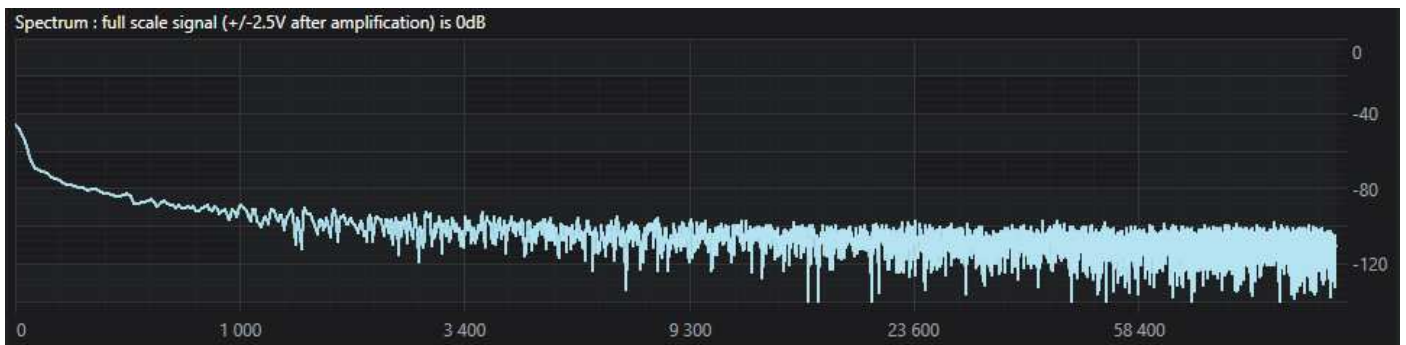

Noise level with single input shorted to ground is below -86dB for frequencies higher than 1kHz. This leads to 15 significant bits in x100 amplification mode.

SINGLE ENDED - PURE SINE INPUT

PURE SINE 100mV F=1kHz

GAIN X1

WAVEFORM AND SPECTROGRAM

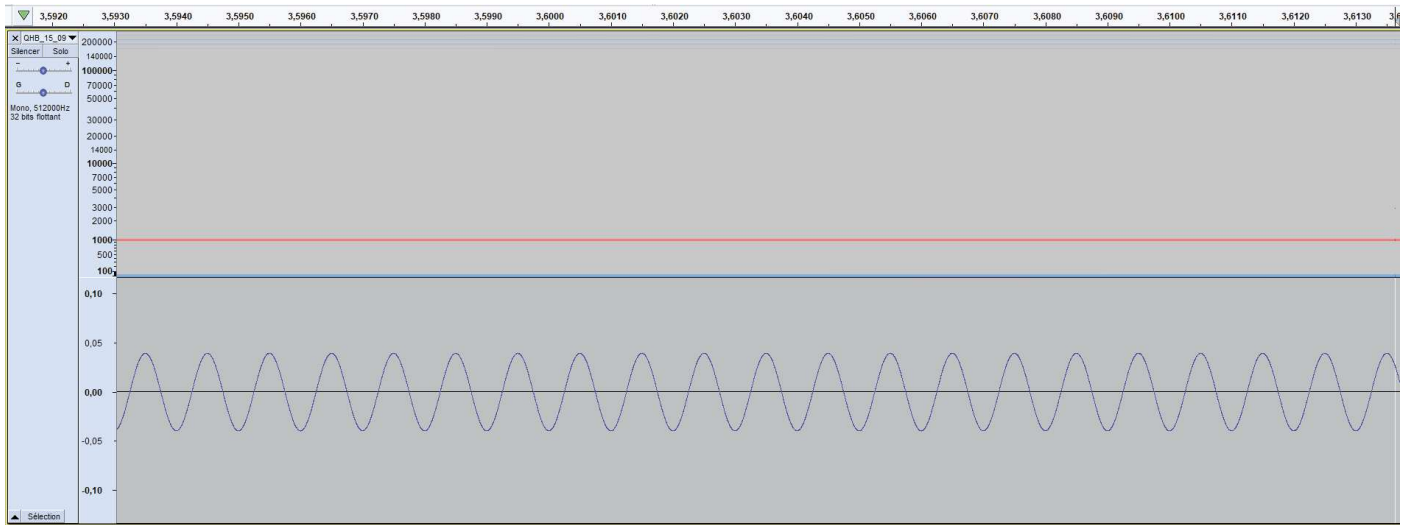

SPECTRUM

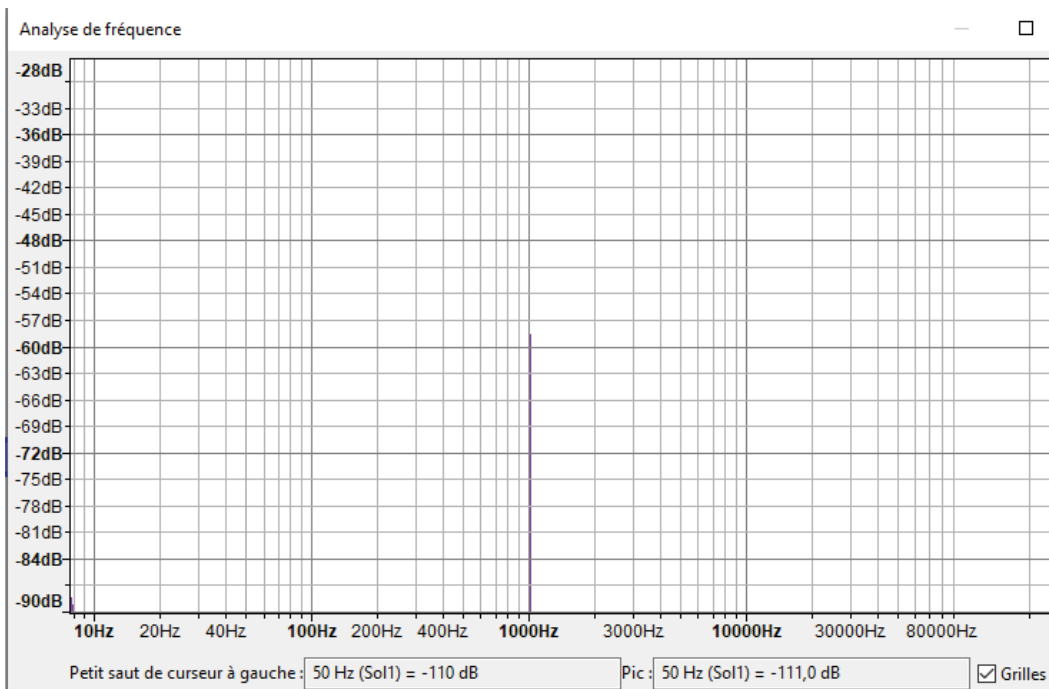

Noise level below **-110dB**

GAIN X10

WAVEFORM AND SPECTROGRAM

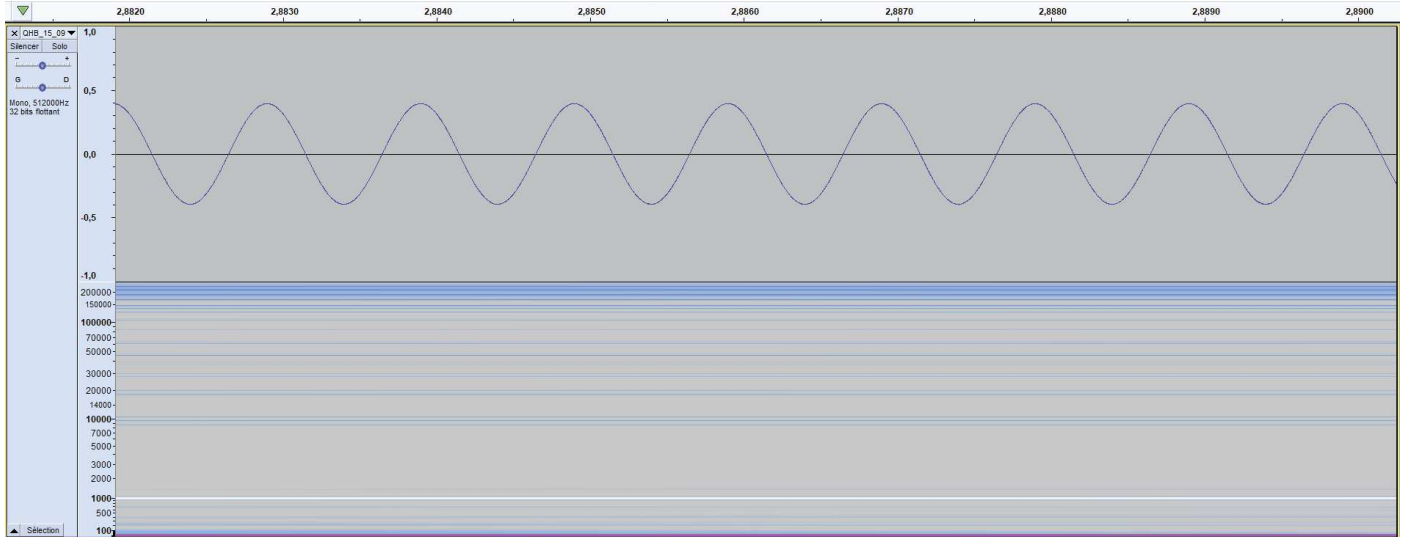

SPECTRUM

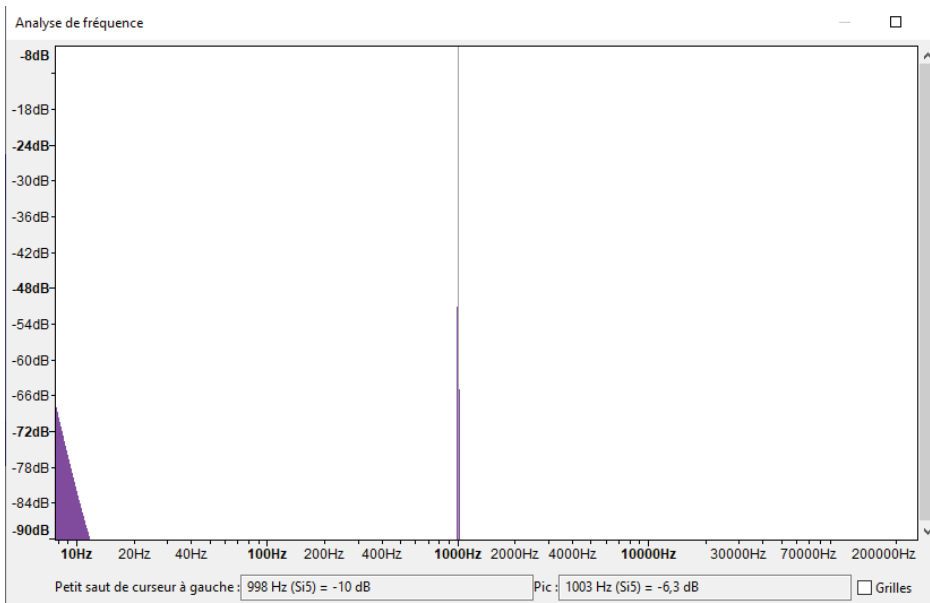

Noise level below **-110dB**

PURE SINE 20mV F=1kHz

GAIN X50

WAVEFORM AND SPECTROGRAM

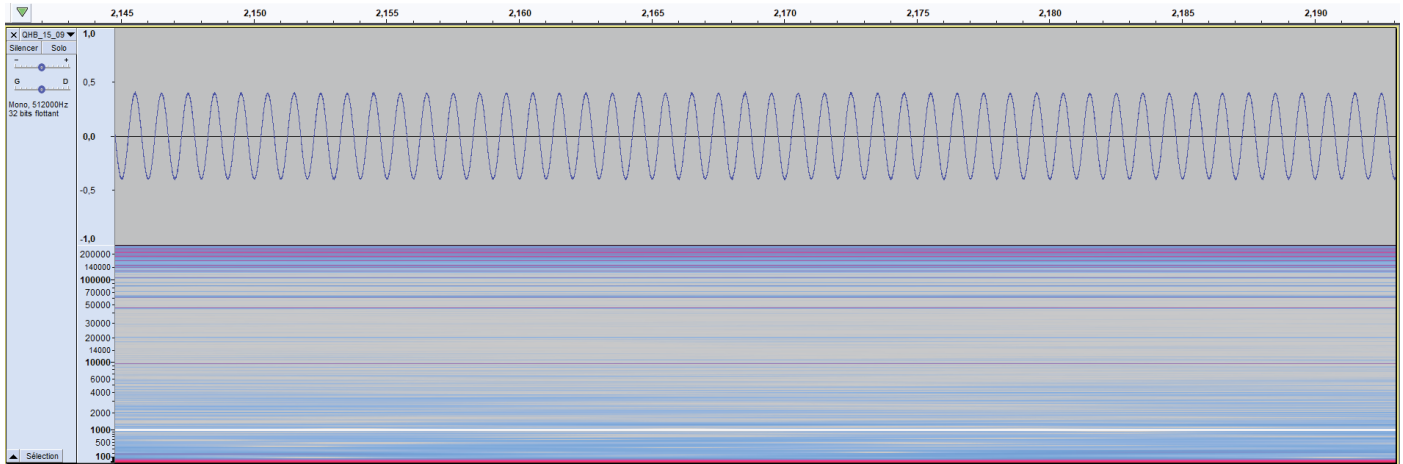

SPECTRUM

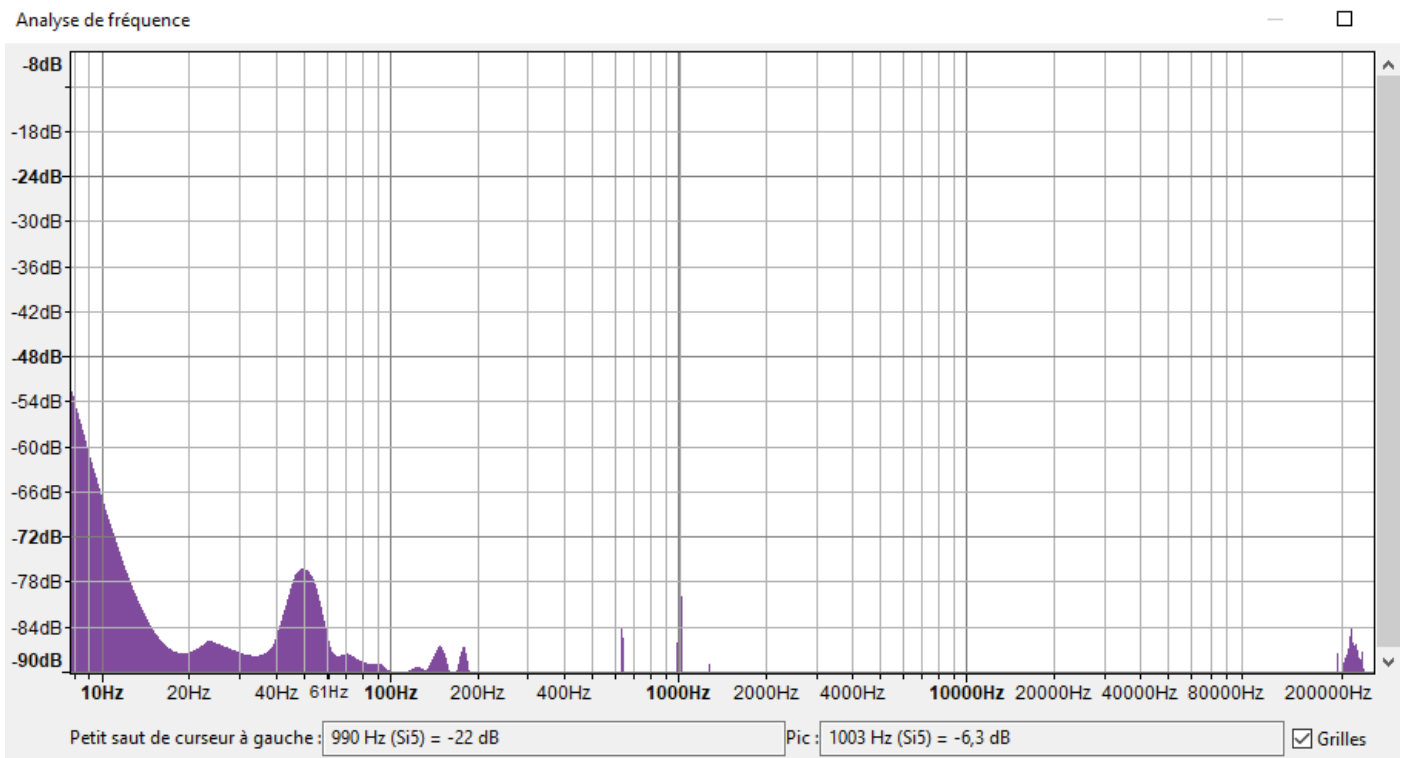

Noise level below **-110dB**

GAIN X100

WAVEFORM AND SPECTROGRAM

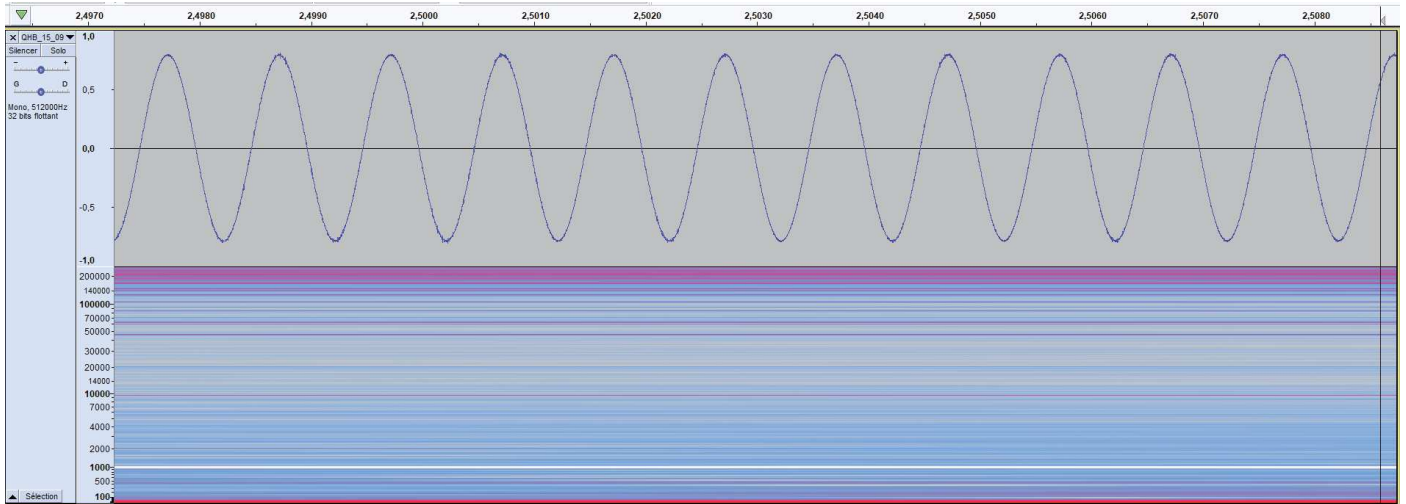

SPECTRUM

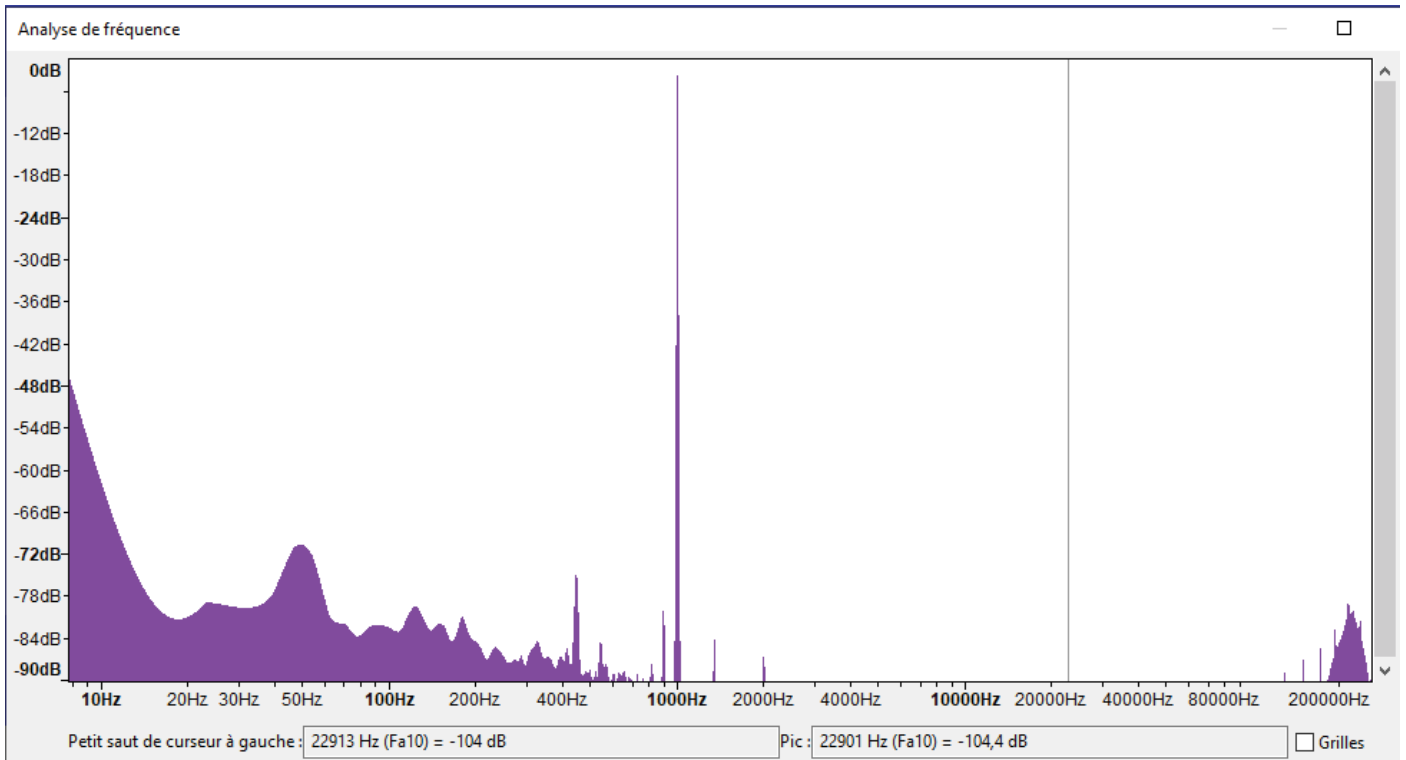

Noise level below **-104dB**

SINGLE ENDED - SWEEP INPUT

SWEEP SINE 100mV F=1Hz to 256kHz

GAIN X1

WAVEFORM AND SPECTROGRAM

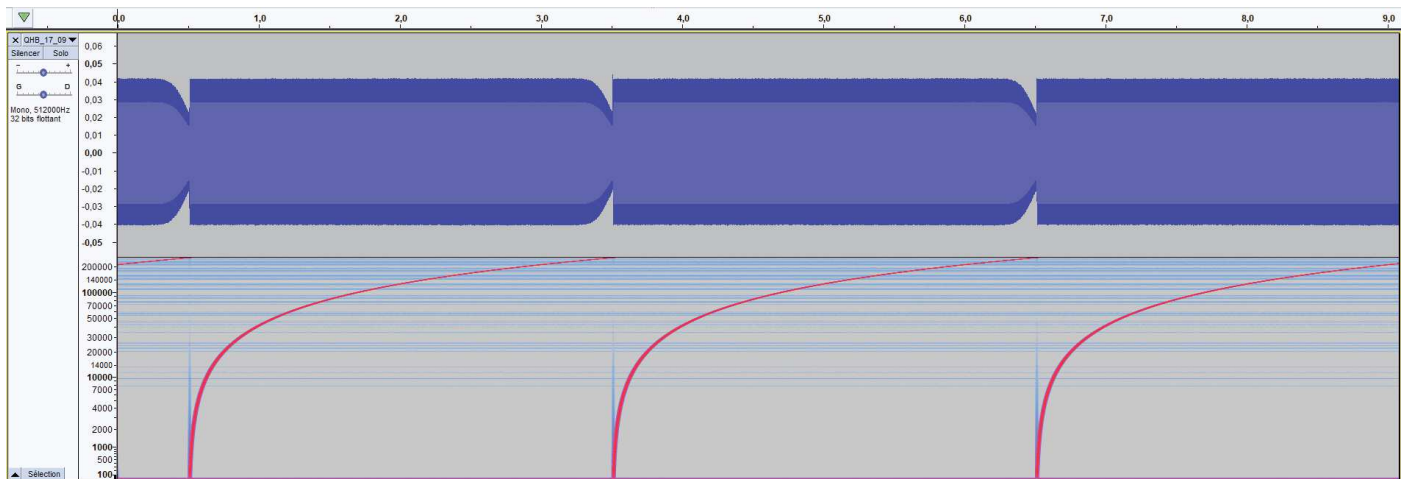

In x1 mode and with a sampling frequency of 512kps, gain is constant for all input frequencies in a range going from 1Hz to 230kHz. An attenuation happens after (up to 50% at max signal frequency).

GAIN X10

WAVEFORM AND SPECTROGRAM

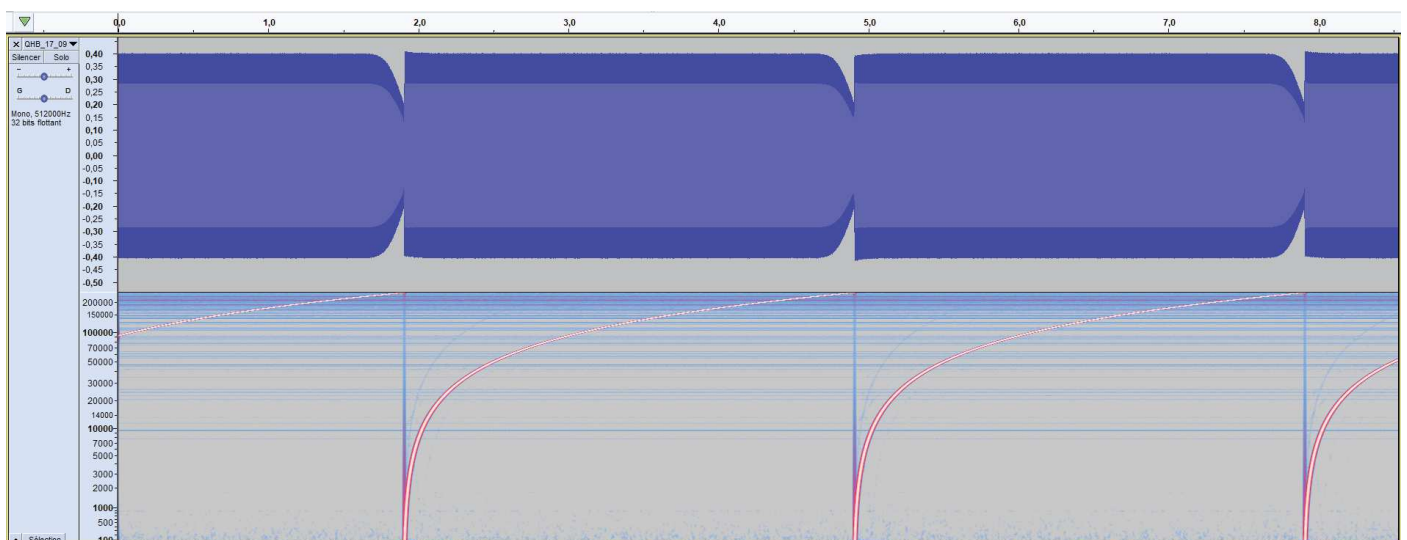

QHB

In x10 mode and with a sampling frequency of 512ksps, gain is constant for all input frequencies in a range going from 1Hz to 230kHz. An attenuation happens after (up to 50% at max signal frequency).

SWEEP SINE 20mV F=1Hz TO 256kHz

GAIN X50

WAVEFORM AND SPECTROGRAM

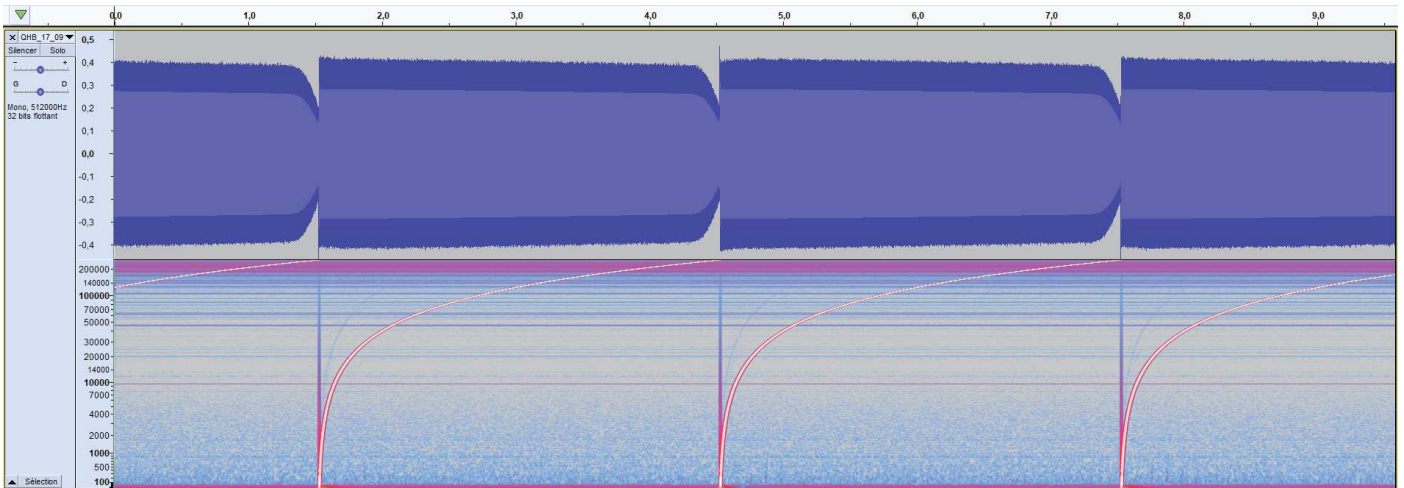

In x50 mode and with a sampling frequency of 512ksps, gain is close to be constant for all input frequencies in a range going from 1Hz to 230kHz. An attenuation happens after (up to 50% at max signal frequency).

GAIN X100

WAVEFORM AND SPECTROGRAM

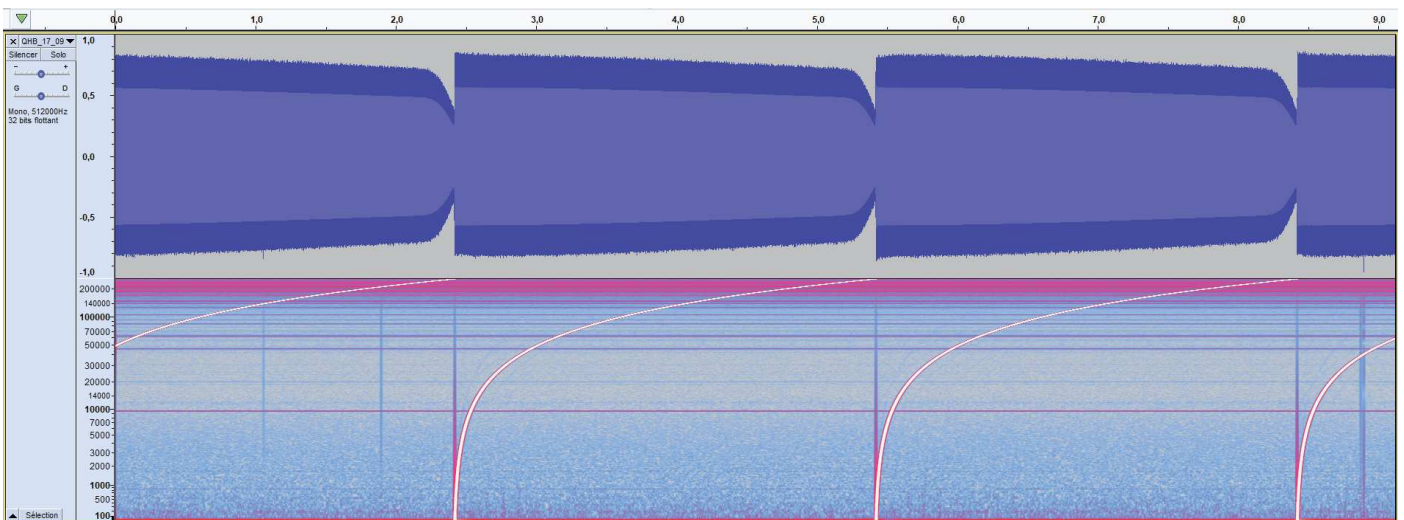

QHB

In x100 mode and with a sampling frequency of 512ksps, gain is close (a progressive attenuation of less than 15% happens as frequency increases) to be constant for all input frequencies in a range going from 1Hz to 230kHz. An attenuation happens after (up to 50% at max signal frequency).

CHECK-LIST

- Check the uSD is correctly set.
- Check the batteries are fully charged and properly placed.
- Check that the switch or jumper is in place.

FAQ

GUARANTEE

SMIoT is not responsible for leakage or immersion inside the tube. If damaged, spare O-rings are provided, or available on request to SMIoT within 15 days if necessary. It is impossible that leakage can occur unless the above instructions are not followed.

REMARKS / MISCELLANEOUS

INFORMATION ON THE STATUS OF LEDs:

We advise you to check the status of the LEDs to detect any false manipulation

The LED **GREEN** indicates that the system has recognized the MSD device, and is ready to start acquisitions. The LED **ORANGE** indicates that the system is being recorded. Finally, the LED **RED** indicates a potential problem: permanently lit: critical error (fatal error).

FUSE REPLACEMENT:

A protection fuse is present on the QHB. It prevents QHB from being damaged in case of overcurrent.

It has to be 2A Max.



NOTES:

The storage medium is **mandatory** in the case of stand-alone operation. If a system error in this case, restart the system.

MECHANICAL INFORMATION

QHB MOTHERBOARD V2 DRAWING

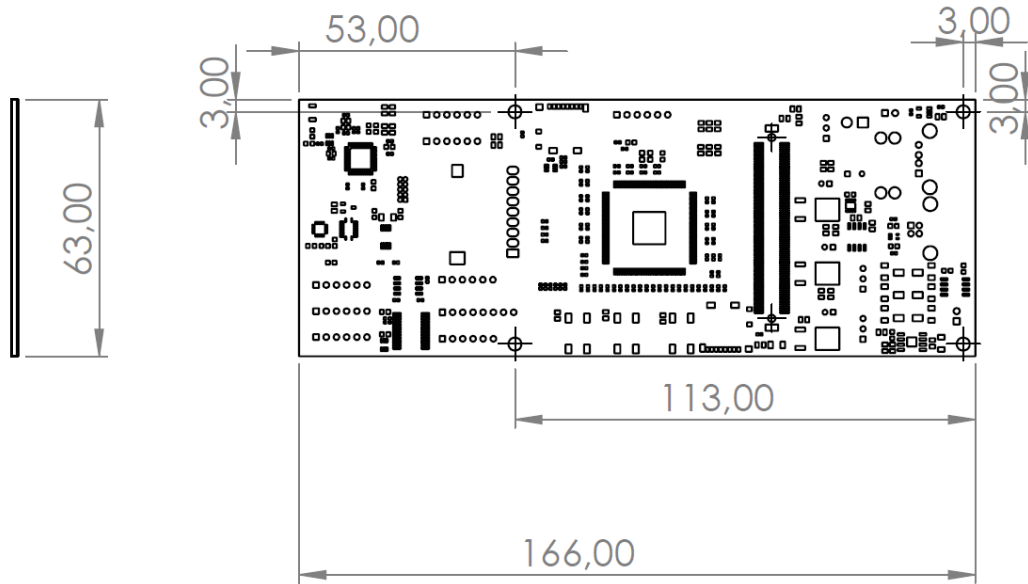

ORIENTATION OF AXES (IMU)

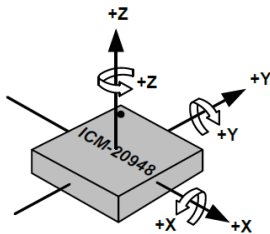

Figure 12. Orientation of Axes of Sensitivity and Polarity of Rotation

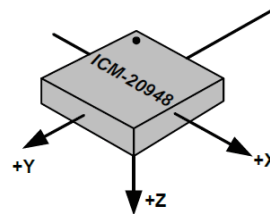
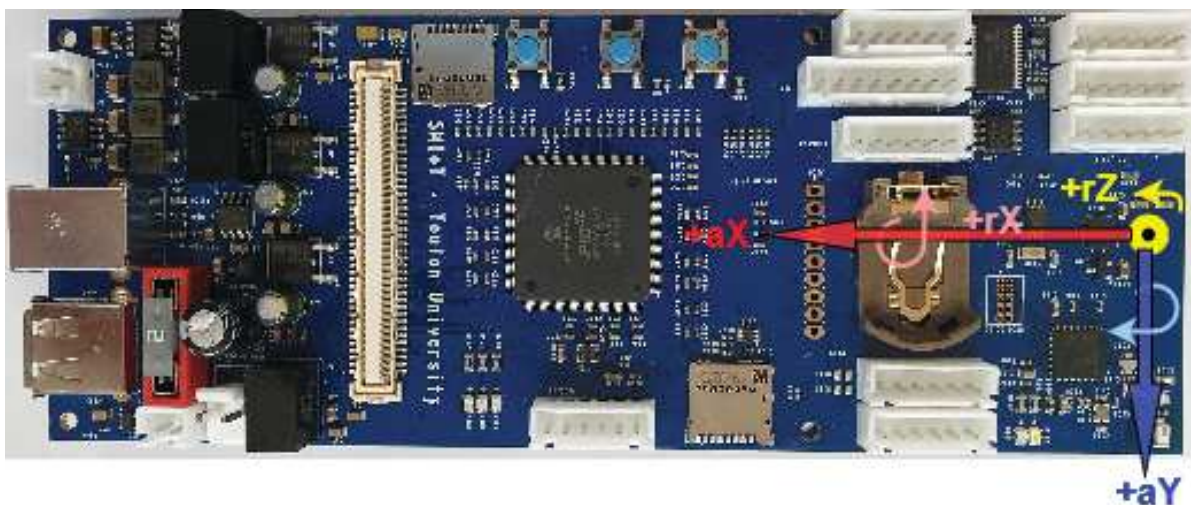
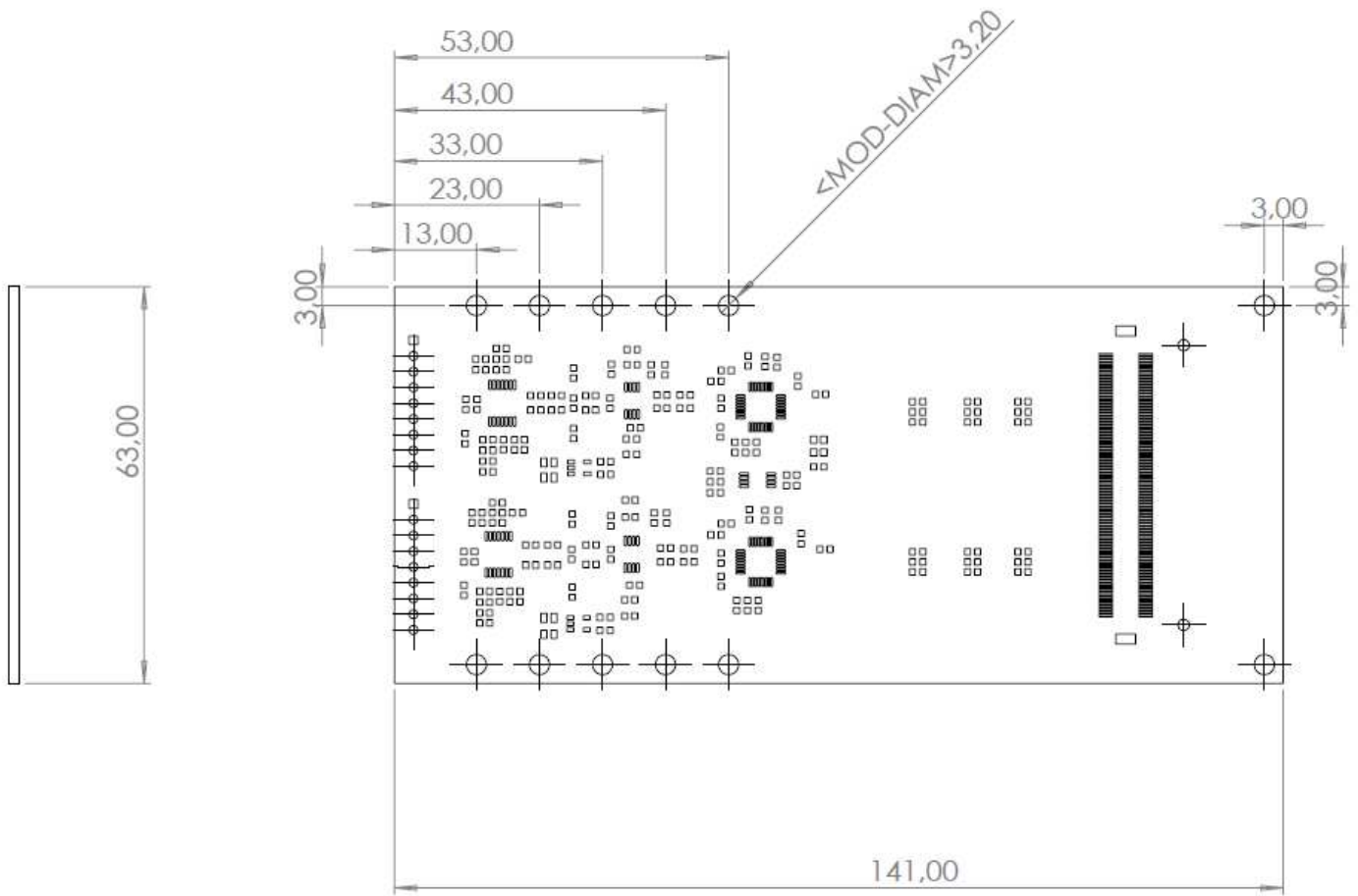

Figure 13. Orientation of Axes of Sensitivity for Magnetometer



QHB DAUGHTER BOARD V2 DRAWING



QHB DAUGHTER BOARD V3 DRAWING (CURRENT VERSION)

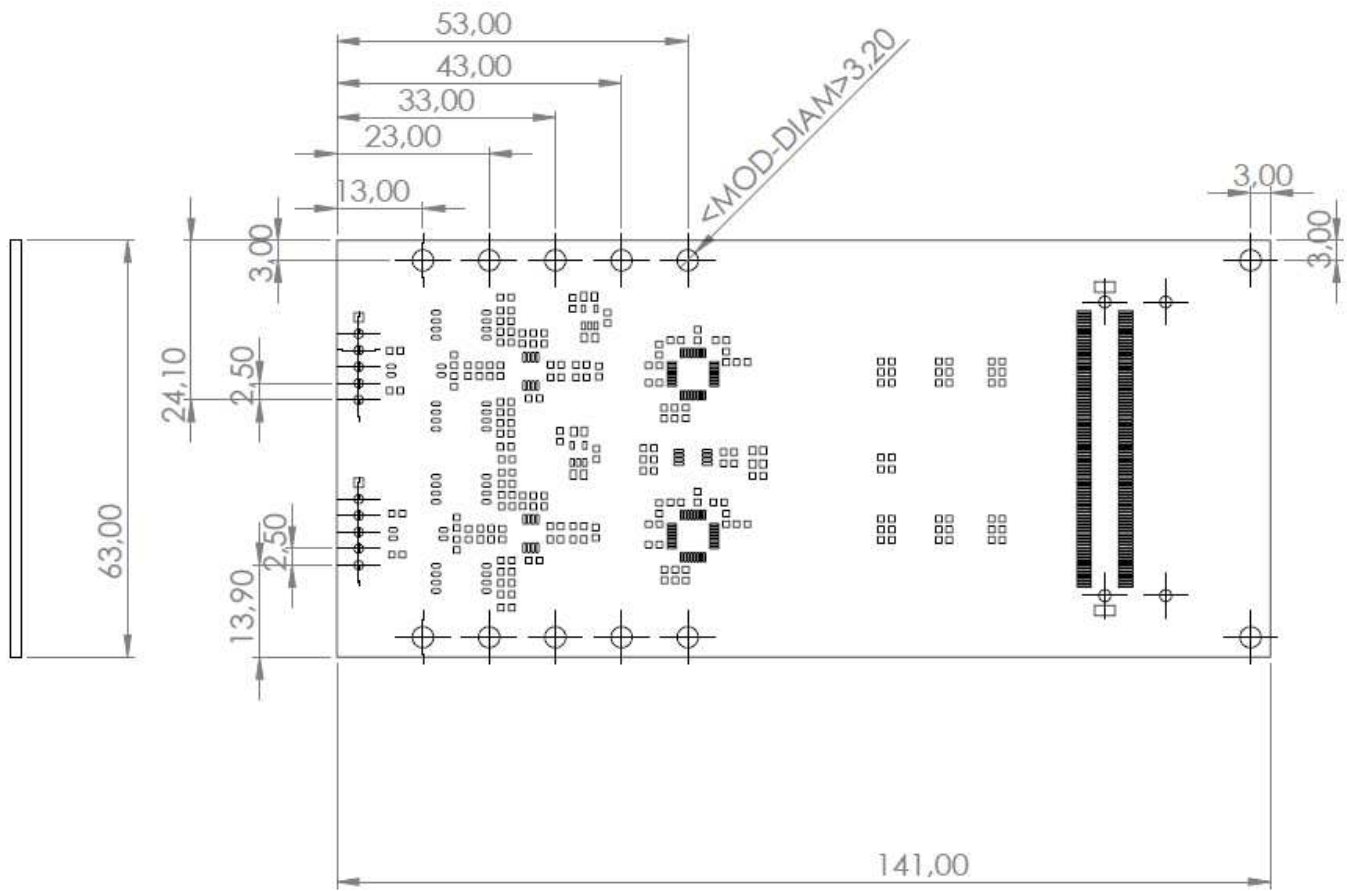

CONTACT US

- Website of the technology platform at: <http://smiot.univ-tln.fr/> with updates of the documentation and french version.

Website of the University of Toulon <http://www.univ-tln.fr/>

- Email technology platform: smiot@univ-tln.fr
- Email responsible of the technology platform: vgies@univ-tln.fr, vgies@hotmail.com
- Email responsible of scientific studies: glotin@univ-tln.fr
- Email design engineer: valentin.barchasz@gmail.com

TELEPHONE : Valentin Gies: +33 (0) 6 28 35 76 85

Address :

IUT GEII Toulon

Plateforme SMIoT Bat. E106

Université de Toulon

Avenue de l'Université - BP 20132

83957 La Garde Cedex

FRANCE

contact for delivery : 06 28 35 76 85